

MINISTRY OF TRANSPORT
CIVIL AVIATION AUTHORITY OF VIETNAM



AIRPORT SERVICES MANUAL
Control of Obstacles

**Hướng dẫn việc thực hiện quy định, khuyến cáo thực
hành của ICAO (Doc 9137 Part 6) về Kiểm soát
chướng ngại vật**

(GM 1.6)

Issued herewith Decision 993/QĐ-CHK dated 04th May 2024

First Edition
Ha Noi, May 2024

RECORD OF AMENDMENTS

Date of issue	Subject(s)/ Amendment	Source	Effective date	Note
04 th May 2024	First Edition	ICAO Doc 9137 - Part 6 (1983)	04 th May 2024	

TABLE OF CONTENTS

Chapter 1.....	8
SURFACES	8
1.1 GENERAL	8
1.2 MAS 1 - OBSTACLE LIMITATION SURFACE	8
1.3 PANS-OPS SURFACES.....	14
1.4. INNER TRANSITIONAL AND BALKED LANDING SURFACES VERNUS Y SURFACES AND MISSED APPROACH SURFACE	17
1.5. BACKGROUND OF HIE COLLISION RISIK MODEL.....	21
Chapter 2.....	23
CONTROLLING OBSTACLES AT AN AIRPORT.....	23
2.1. BACKGROUND.....	23
2.2 LEGAL AUTHORITY AND RESPONSIBILITY	24
2.3 HEIGHT ZONING.....	25
2.4 PURCHASE OF EASEMENTS AND PROPERTY RIGHTS	27
2.5 NOTIFICATION OF PROPOSED CONSTRUCTION.....	28
2.6 ESTABLISHMENT OF OBSTACLE LIMITATION SURFACES	30
2.7 OBSTACLE SURVEYS	32
2.8 REMOVAL OF OBSTACLES	32
2.9 SHIELDING.....	33
2.10 MARKING AND LIGHTING OF OBSTACLES.....	34
2.11 REPORTING OF OBSTACLES	35
Chapter 3.....	37
TEMPORARY HAZARDS.....	37
3.1 INTRODUCTION.....	37
3.2 RESTRICTIONS FOR NON - INSTRUMENT AND	38
ON - PRECISION APPROACH RUNWAYS	38
3.3 RESTRICTIONS FOR PRECISION APPROACH RUNWAYS	40
3.4 PRE-CONSTRUCTION MEETING	41
Chapter 4.....	42
OBSTACLE SURVEYS	42
4.1 AUSTRALIAN PRACTICE.....	42
4.2 UNITED KINGDOM PRACTICE	52
4.3 UNITED STATES OF AMERICA PRACTICE	58
Chapter 5.....	65
AIRPORT EQUIPMENT AND INSTALLATIONS.....	65
WHICH MAY CONSTITUTE OBSTACLES.....	65
5.1 INTRODUCTION.....	65
5.2 FRANGIBILITY.....	66
5.3 TYPES OF AIRPORT EQUIPMENT	66

AND INSTALLATIONS WHICH MAY CONSTITUTE OBSTACLES	66
Appendix 1	73
Illustrations of Obstacle Limitation Surfaces Other Than Those Constituting an Obstacle-Free Zone	73
Appendix 2	76
Model Zoning Ordinance to Limit Height of Objects Around an Airport.....	77
Appendix 3.....	95
States' Practices on Shielding.....	95

RECORD OF AMENDMENTS

Date of issue	Subject(s)/ Amendment	Source	Effective date	Note
04 th May 2024	First Edition	ICAO Doc 9137 Part 6 (1983)	04 th May 2024	

FOREWORD

1. BACKGROUND

1.1. Pursuant to Article 11, Clause 2 of the Decree No. 66/2015/ND-CP dated 12th August 2015 on the Civil Aviation Authority stipulating the function and responsibility of the Civil Aviation Authority of Viet Nam (CAAV) in guiding the implementation of Standards and Recommended Practices of ICAO;

1.2. Pursuant to Article 8, Clause 10 of the Decree No. 05/2021/ND-CP dated 25th January 2021 on the management and operation of airport and aerodrome stipulating the function and responsibility in providing guidance on and issue professional instructions related to management and operation of airports/aerodromes in line with regulations of law and regulations of ICAO (including: documents providing guidelines for airport/aerodrome design; documents providing guidelines for operation and assurance of security and safety at airports/aerodromes)

1.3. Pursuant to Article 4, Clause 6 of the Decree No. 0/5/2021/ND-CP dated 25th January 2021 stipulating details of airport/aerodrome infrastructure shall be designed and operated according to the standards of International Civil Aviation Organization (ICAO)

1.4 This Procedures for Air Navigation Services - Aerodrome is issued by CAAV specifying the details of provisions to be met by the AO organizations, originators related. The details in this Manual are based on those stipulated in ICAO Doc 9981-Part 6 [as in force and amended from time to time by the Council of the International Civil Aviation Organization (ICAO)] and with such modifications as may be determined by CAAV to be applicable in Viet Nam.

1.5. Amendments to this document are the responsibility of the Airport Management Department - CAAV. Readers should forward advice of errors, inconsistencies or suggestions for improvement to this Manual to the addressee stipulated below.

Airport Management Department - CAAV
No. 119, Nguyen Son Street, Gia Thuy ward, Long Bien district, Ha Noi.
Email Address: and@caa.gov.vn.

2. SCOPE AND PURPOSE

2.1 This part of the Airport Services Manual includes guidance on the control of obstacles in the vicinity of airports. Much of the material included herein is closely associated with the specifications contained in MAS 1 - Aerodromes. The main purpose of this manual is to encourage the uniform application of those specifications and to provide information and guidance to States. The significant additions to the manual during the current revision are:

a) information on obstacle limitation surfaces for precision approach runways category I and on the relationship between the MAS 1 and PANSL-OPS surfaces (Chapter 1); and

b) guidance on controlling obstacles at an airport (Chapter 2 and Appendix 2).

Chapter 4 and Appendix 3 of this manual, which deal with obstacle surveys and shielding, respectively, are largely based on updated material provided by States and are, therefore, believed to be current. Should a State, at any time, consider that any portion of this material is out of date, it should inform the Secretary General of this and, if possible, provide revised material.

Chapter 1

SURFACES

1.1 GENERAL

1.1.1 The effective utilization of an aerodrome may be considerably influenced by natural features and manmade constructions inside and outside its boundary. These may result in limitations on the distances available for take-off and landing and on the range of meteorological conditions in which take-off and landing can be undertaken. For these reasons certain areas of the local airspace must be regarded as integral parts of the aerodrome environment. The degree of freedom from obstacles in these areas is as important to the safe and efficient use of the aerodrome as are the more obvious physical requirements of the runways and their associated strips.

1.1.2 The significance of any existing or proposed object within the aerodrome boundary the vicinity of the aerodrome is assessed by the use of two separate sets of criteria defining airspace requirements. The first of these comprises the obstacle limitation surfaces particular to a runway and its intended use detailed in Chapter 4 of MAS 1. The broad purpose of these surfaces is to define the volume of airspace that should ideally be kept free from obstacles in order to minimize the dangers presented by obstacles to an aircraft, either during an entirely visual approach or during the visual segment of an instrument approach. The second set of criteria comprises the surfaces described in the Procedures for Air Navigation Services - Aircraft Operations PANS-OPS) (*Doc 8168*), *Volume II - Construction of visual and Instrument Flight Procedures*. The PANS-OPS surfaces are intended for use by procedure designers for the construction of instrument flight procedures and for specifying minimum safe altitudes/heights for each segment of the procedure. The procedure and/or minimum heights may vary with aeroplane speed, the navigational aid being used, and in some cases the equipment fitted to the aeroplane.

1.1.3 The surfaces of MAS 1 are intended to be of a permanent nature. To be effective, they should therefore be enacted in local zoning laws or ordinances or as part of a national planning consultation scheme. The surfaces established should allow not only for existing operations but also for the ultimate development envisaged for each aerodrome. There may also be a need to restrict obstacles in areas other than those covered by MAS 1 if operational minima calculated using the PANS-OPS criteria are not, to be increased, thereby limiting aerodrome utilization.

1.2 MAS 1 - OBSTACLE LIMITATION SURFACE

1.2.1 Function of the surfaces

1.2.1.1 The following paragraphs describe the function of the various surfaces defined in Chapter 4, and in certain instances include additional information concerning their characteristics. For the benefit of the reader, several illustrations of obstacle limitation surfaces are included in Appendix 1.

1.2.2. Outer horizontal surface

1.2.2.1 In the experience of some States, significant operational problems can arise from the erection of tall structures in the vicinity of airports beyond the areas currently recognized in MAS 1 as areas in which restriction of new construction may be necessary. The operational implications fall broadly under the headings of safety and efficiency

1.2.2.2 *Safety implications.* It is particularly desirable to review carefully any proposal to erect high masts or other skeletal structures in areas which would otherwise be suitable for use by aircraft on wide visual circuits, on arrival routes towards the airport or circuit, or on departure or missed approach climb-paths. Avoidance by marking or lighting cannot be relied upon in view of the relatively inconspicuous character of these structures, especially in conditions of reduced visibility, and notification of their existence will similarly not always guarantee avoidance.

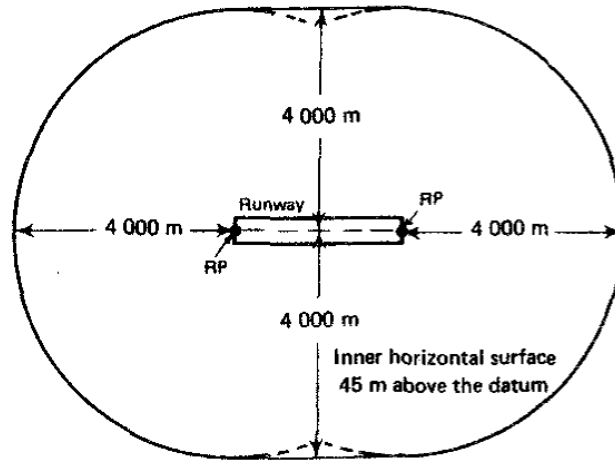

Figure 1-1. Inner horizontal surface for a single runway
(where the runway code number is 4)

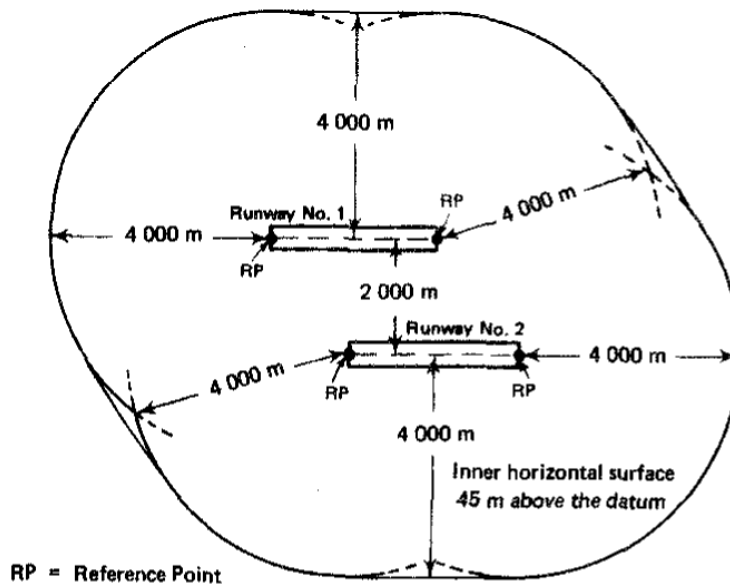

Figure 1-2. Composite inner horizontal surface for two parallel runways
(where the runway code number is 4)

1.2.2.3 *Efficiency implications.* If tall structures are erected in or near areas otherwise suitable for instrument approach procedures, increased procedure heights may need to be adopted, with consequent adverse effects on regularity and on the duration of the approach procedure, such as the denial of useful altitude allocations to aircraft in associated holding patterns. Such structures may furthermore limit desirable flexibility for radar vectored initial approaches and the facility to turn en route during the departure climb or missed approach.

1.2.2.4 In view of these potentially important operational considerations, authorities may consider it desirable to adopt measures to ensure that they have advance notice of any proposals to erect tall structures. This will enable them to study the aeronautical implications and take such action as may be at their disposal to protect aviation interests. In assessing the operational effect of proposed new construction, tall structures would not be of immediate significance if they are proposed to be located in:

- a) an area already substantially obstructed by terrain or existing structures of equivalent height; and
- b) an area which would be safely avoided by prescribed procedures associated with navigational guidance when appropriate.

1.2.2.5 As a broad specification for the outer horizontal surface, tall structures can be considered to be of possible significance if they are both higher than 30 m above local ground level, and higher than 150 m above aerodrome elevation within a radius of 15 000 m of the centre of the airport where the runway code number is 3 or 4. The area of concern may need to be extended to coincide with the obstacle-accountable areas of PANS-OPS for the individual approach procedures at the airport under consideration.

1.2.3 Inner horizontal surface and conical surface

1.2.3.1 The purpose of the inner horizontal surface is to protect airspace for visual circling prior to landing, possibly after a descent through cloud aligned with a runway other than that in use for landing.

1.2.3.2 In some instances, certain sectors of the visual circling areas will not be essential to aircraft operations and, provided procedures are established to ensure that aircraft do not fly in these sectors, the protection afforded by the inner horizontal surface need not extend into those sectors. Similar discretion can be exercised by the appropriate authorities when procedures have been established and navigational guidance provided to ensure that defined approach and missed approach paths will be followed.

1.2.3.3. Whilst visual circling protection for slower aircraft using shorter runways may be achieved by a single circular inner horizontal surface, with an increase in speed it becomes essential to adopt a race-track pattern (similar to PANS-OPS) and use circular arcs centred on runway ends joined tangentially by straight lines. To protect two or more widely spaced runways, a more complex pattern could become necessary, involving four or more circular arcs. These situations are illustrated at Figures 1-1 and 1-2 respectively.

1.2.3.4 *Inner horizontal surface - elevation datum.* To satisfy the intention of the inner horizontal surface described above, it is desirable that authorities select a datum elevation from which the top elevation of the surface is determined. Selection of the datum should take account of:

- a) the elevations of the most frequently used altimeter setting datum points;
- b) minimum circling altitudes in use or required; and
- c) the nature of operations at the airport.

For relatively level runways the choice of datum is not critical, but when the thresholds differ by more than 6 m, the datum selected should have particular regard to the factors above. For complex inner horizontal surfaces (Figure 1-2) a common elevation is not essential, but where surfaces overlap the lower surface should be regarded as dominant.

1.2.4 *Approach and transitional surfaces*

1.2.4.1 These surfaces define the volume of airspace that should be kept free from obstacles to protect an aeroplane in the final phase of the approach-to-land manoeuvre. Their slopes and dimensions will vary with the aerodrome reference code and whether the runway is used for visual, non-precision or precision approaches.

1.2.5 *Take-off climb surface*

1.2.5.1. This surface provides protection for an aircraft on take-off by indicating which obstacles should be removed if possible, and marked or lighted if removal is impossible. The dimensions and slopes also vary with the aerodrome reference code.

1.2.6 *The inner approach, inner transitional and balked landing surfaces*

1.2.6.1 Together, these surfaces (see Figure 1-3) define a volume of airspace in the immediate vicinity of a precision approach runway which is known as the obstacle-free zone (OFZ). This zone shall be kept free from fixed objects, other than lightweight frangibly mounted aids to air navigation which must be near the runway

to perform their function, and from transient objects such as aircraft and vehicles when the runway is being used for category II or III ILS approaches. When an OFZ is established for a precision approach runway category I, it shall be clear of such objects when the runway is used for category I ILS approaches.

1.2.6.2 The OFZ provided on a precision approach runway where the code number is 3 or 4 is designed to protect an aeroplane with a wingspan of 60m on a precision approach below a height of 30 m having been correctly aligned with the runway at that height, to climb at a gradient of 3.33 percent and diverge from the runway center line at a splay no greater than 10 percent. The gradient of 3.33 percent is the lowest permitted for an all-engine-operating balked landing. A horizontal distance of 1.800 from threshold to the start of the balked landing surface assumes that the latest point for a pilot to initiate balked landing is the end of the touchdown zone lighting, and that changes to aircraft configuration to achieve a positive climb gradient with normally require a further distance of 900 m which is equivalent to a maximum time of about 15s. A slope of 33.33 percent for the inner transitional surfaces results from a 3.33 percent climb gradient with a splay of 10 percent. The splay of 10 percent is based upon recorded dispersion data in programmes conducted by two States.

1.2.6.3 The OFZ for a precision approach runway category I where the code number is 1 or 2 is designed to protect an aeroplane with a wing span of 30 m to climb at a gradient of 4 percent and diverge from the runway centre line at a splay no greater than 10 percent. The gradient of 4 percent is that of the normal take-off climb surface for these aeroplanes. When allied to a 10 percent splay, it results in a slope for the inner transitional surfaces of 40 percent. The balked landing surface originates at 60 m beyond the far end of the runway from threshold and is coincident with the take-off climb surface for the runway.

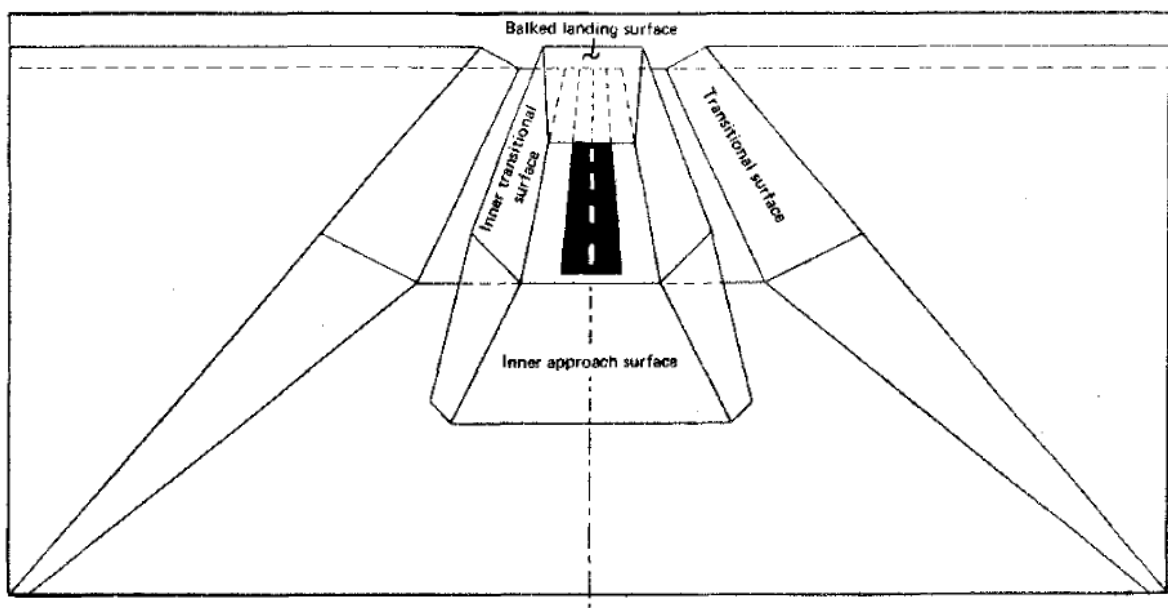

Figure 1-3.

1.3 PANS-OPS SURFACES

1.3.1 General

1.3.1.1 The PANS-OPS surfaces are intended for use by procedure designers primarily in the construction of instrument flight procedure which are designed to safeguard an aeroplane from collision with obstacles when flying on instruments. In designing procedure, the designer will determine areas (horizontally) needed for various segments of the procedure. Then he will analyse the obstacles within the determined areas, and based on the analysis he will specify minimum safe altitudes/heights for each segment of the procedure for use by pilots.

1.3.1.2 The minimum safe altitude/height specified for the final approach phase of a flight is called "obstacle clearance altitude/height (OCA/H)". A missed approach procedure initiated by the pilot at or above this altitude/height will ensure that, even if the pilot has no outside visual reference to the ground at any point, the aeroplane will pass safely above all potentially dangerous obstacles. The pilot may descend below the OCA/H only if he has visually confirmed that the aeroplane is correctly aligned with the runway and that there are sufficient visual cues to continue the approach. The pilot is permitted to discontinue the approach at any point below the OCA/H, e.g. if the required visual reference ceases to be available. Such a late missed approach is called bailed landing. Because the initiation point of the bailed landing procedure is known more accurately than the initiation point of the missed approach procedure, a smaller airspace needs to be protected.

Note. - Not all of the above is applicable to category III operations carried out with no decision height.

1.3.1.3 The size and dimensions of the obstacle-free airspace needed for the approach, for the missed approach initiated at or above the OCA/H and for the visual manoeuvring (circling) procedure are specified in PANS-OPS. Aeroplanes continuing their descent below the specified OCA/H, and therefore having visual confirmation that they are correctly aligned, are protected from obstacles by the MAS 1 obstacle limitation surfaces and related obstacle limitation and marking/lighting requirements. Similarly, the MAS 1 surfaces provide protection for the bailed landing. In other than low visibilities, it may be necessary for the pilot to avoid some obstacles visually.

1.3.1.4 The airspace required for an approach (including missed approach and visual circling) is bounded by surfaces which do not usually coincide with the obstacle limitation surfaces specified in MAS 1. In the case of a non-precision approach, missed approach and visual manoeuvring, the surfaces have a rather

simple form. Typical cross-sections of such obstacle-free airspace are shown in Figures 1-4 and 1-5. The plan view of such an obstacle-free area depends on the characteristics of the navigational facility used for the approach but not on the characteristics of the aeroplane. A typical plan view is shown in Figure 1-6.

1.3.1.5 In the case of a precision approach, the form of the obstacle-free airspace becomes more complicated because it depends on several variables, such as aeroplane characteristics (dimensions, equipment, performance) and ILS facility characteristics (facility performance category, reference datum height, localizer course width and the distance between the threshold and localizer antenna). The airspace can be bounded by plane or curved surfaces which have resulted in "basic ILS surfaces", "obstacle assessment surfaces (OAS)" and the Collision Risk Model (CRM) (see further, 1.3.2 to 1.3.4 below).

1.3.2 *Basic ILS surfaces.* The "basic ILS surfaces" defined in PANS-OPS represent the simplest form of protection for ILS operations. These surfaces are extensions of certain MAS 1 surfaces, referenced to threshold level throughout and modified after threshold to protect the instrument missed approach. The airspace bounded by the basic ILS surfaces is however usually too conservative and therefore another set of surfaces, "obstacle assessment surfaces", is specified in PANS- OPS.

1.3.3 *Obstacle assessment surfaces.* The obstacle assessment surfaces (OAS) establish a volume of airspace, inside which it is assumed the flight paths of aeroplanes making ILS approaches and subsequent missed approaches will be contained with sufficiently high probability. Accordingly, aeroplanes need normally only be protected from those obstacles that penetrate this airspace; objects that do not penetrate it usually present no danger to ILS operations. However, if the density of obstacles below the OAS is very high, these obstacles will add to the total risk and may need to be evaluated (see 1.5.2 below). The above airspace (funnel) is illustrated in Figure I- 7. It is formed by a set of plane surfaces, an approach surface (W), a ground or "footprint" surface (A) and a missed approach surface (Z); all bounded by side surfaces (X and Y). The dimensions of the surfaces are tabulated in PANS-OPS, Volume II. The lateral boundaries of the funnel represent estimates of the maximum divergence of an aeroplane from the runway centre line during the approach and missed approach so that the probability of an aeroplane touching the funnel at any one point is $1:10^{-7}$ or less. The probable flight paths, both vertical and lateral, for aeroplanes tracking the ILS beams during an approach, have been based on a consideration of possible tolerances in both the ground and airborne navigational equipment and the extent to which the pilot may allow the aeroplane to deviate from the beam whilst attempting to follow the ILS guidance (pilotage). The probable flight paths in the missed approach are based on arbitrary assumptions of minimum climb performance and maximum splay angle of the aeroplane in a missed approach manoeuvre. Note that, as mentioned in 1.3.1.5, the precise dimensions of a funnel

do vary with a number of factors. Having defined this volume of airspace, simple calculations allow an OCA/H to be calculated which would protect the aeroplane from all obstacles. The difference between the basic ILS surfaces and the OAS is that the dimensions of the latter are based upon a collection of data on aircraft ILS precision approach performance during actual instrument meteorological conditions, rather than existing MAS 1 surfaces.

1.3.4. *ILS Collision Risk Model (CRM)*. The approach funnel of the OAS was designed against an over-all risk budget of one accident in 10 million approaches (i.e. a target level of safety of 1×10^{-7} per approach). One consequence was that an operational judgement was required to assess the acceptable density of obstacles in the vicinity of the OAS, although they might be below the surface itself. In addition, the OAS were overprotective in certain areas, because they were relatively simple plane surfaces designed to enclose a complex shape and to allow easy manual application. As a consequence of these factors, a more sophisticated method of relating obstacle heights and locations to total risk and OCA/H was developed. This method was embodied in a computer programme called the Collision Risk Model (CRM). It enables a far more realistic assessment of the effects of obstacles, both individually and collectively. The actual construction of the approach funnel (illustrated in Figure 1-8) involves some fairly detailed mathematics and cannot be done manually. However, its application is easy, because all calculations will be done by a computer. The Collision Risk Model is widely available. (ICAO offers the service and the programme is available for purchase to interested users. For further details see 1.5 below.)

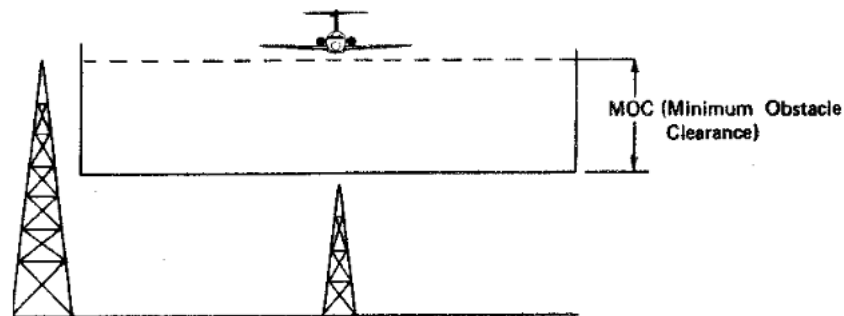

Figure 1-4

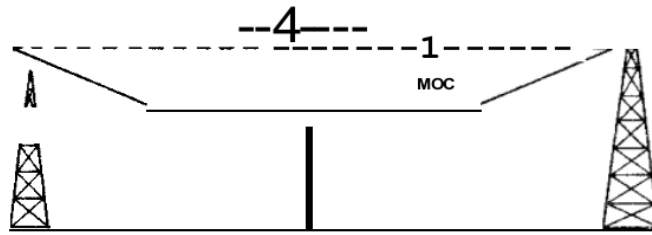

Figure 1-5.

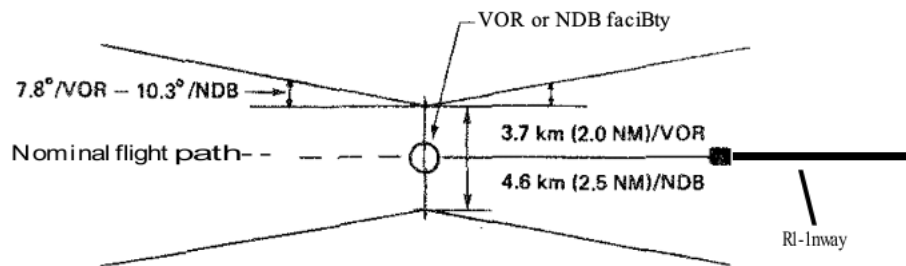

Figure 1-6

1.3.5 *Visual manoeuvring (circling procedure)*. Visual manoeuvring (circling procedure), described in the PANS-OPS, is a visual extension of an instrument approach procedure. The size or the area for a visual manoeuvring (circling) varies with the flight speed. It is permissible to eliminate from consideration a particular sector where a prominent obstacle exists by establishing appropriate operational procedures. In many cases, the size of the area will be considerably larger than that covered by the MAS 1 inner horizontal surface. Therefore circling altitudes/heights calculated according to PANS-OPS for actual operations may be higher than those based only on obstacles penetrating the inner horizontal surface area.

1.3.6 *Operational minima*. In conclusion, it must be stressed a runway protected only by the obstacle limitation surfaces of MAS 1 will not necessarily allow the achievement of the lowest possible operational minima if it does not, at the same time, satisfy the provisions of the PANS-OPS. Consequently, consideration needs to be given to objects which penetrate the PANS-OPS surfaces, regardless of whether or not they penetrate an Armex 14 obstacle limitation surface, and such obstacles may result in an operational penalty.

1.4. INNER TRANSITIONAL AND BALKED LANDING SURFACES

VERNUS Y SURFACES AND MISSED APPROACH SURFACE

1.4.1 When establishing the obstacle free zone for precision approach category II operations, the Obstacle Clearance Panel (OCP) created the inner

transitional and balked landing surfaces. When developing the new approach procedures contained in PANS-OPS, Volume II, First Edition, instead of using these surfaces for obstacle assessment, the OCP used the Y surface and a new surface referred to as the missed approach surface (see Figure 1-7). Both sets of surfaces are required. In determining the need for the two sets of surfaces, the difference between the objectives of MAS 1 and PANS-OPS has to be taken into account. The surfaces in PANS-OPS are intended for assessing the impact of objects on the determination of the obstacle clearance height, which in turn is used in determining approach minima and ensuring that the minimum acceptable safety level is achieved (i.e. probability of collision with objects is not more than $1:10^{-7}$). MAS 1 surfaces are intended to define the limits around airports to which objects can extend. A further difference, and one specifically associated with these surfaces, is that PANS-OPS provides obstacle assessment for operations down to the obstacle clearance height and, for most aeroplanes, for a missed approach with one engine inoperative executed above or at this height. The Annex- 14 surfaces are intended to protect a landing from the obstacle clearance height, or a balked landing executed with all engines operative and initiated below the obstacle clearance height. In the missed approach case, the PANS-OPS surfaces (see 1.3.2 to 1.3.4 above), which include a missed approach surface, are the controlling surfaces. The obstacle assessment surfaces (OAS) fall below a portion of the MAS 1 inner approach surface and below that portion of the transitional surface near the end of the touchdown area. In cases such as these, the MAS 1 surfaces are used to determine OCH. In the landing and balked landing, the inner transitional and balked landing surfaces are the controlling surfaces.

1.4.2 The PANS-OPS and MAS 1 surfaces are different for several reasons. A missed approach is to be executed at or above the obstacle clearance height. At this point, the aircraft can not be assumed to be aligned with the runway as precisely as in the case of a balked landing, as the pilot may never have had visual reference to the runway. The width required for executing the missed approach is therefore wider than for a balked landing; thus the use of the transitional surfaces, which are wider apart than the inner transitional surfaces. Secondly, since the missed approach may be assumed to be executed with one engine inoperative, the climb rate will be less than for a balked landing executed with an engines operating, and consequently the slope of the missed approach surface must be less than that of the balked landing surface. As the missed approach operation by definition has to be initiated at or above the obstacle clearance height, the origin of the missed approach surface may be closer to the threshold than that of the balked landing surface.

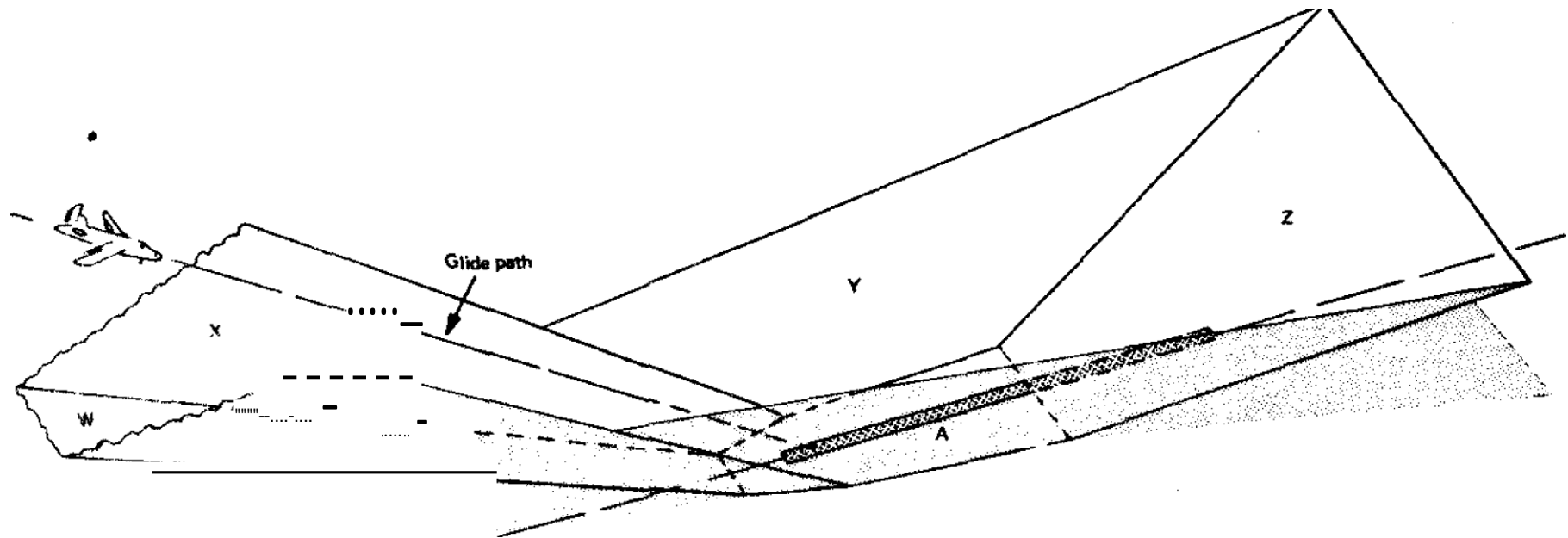

The funnel is formed by the set of 7 surface:

- The **W** and two X approach surface.
- The "footprint" **A**.
- The miMed approach, surface **Z**.
- The two Y transitional surfaces.

Figure 1-7. The approach funnel (OAS)

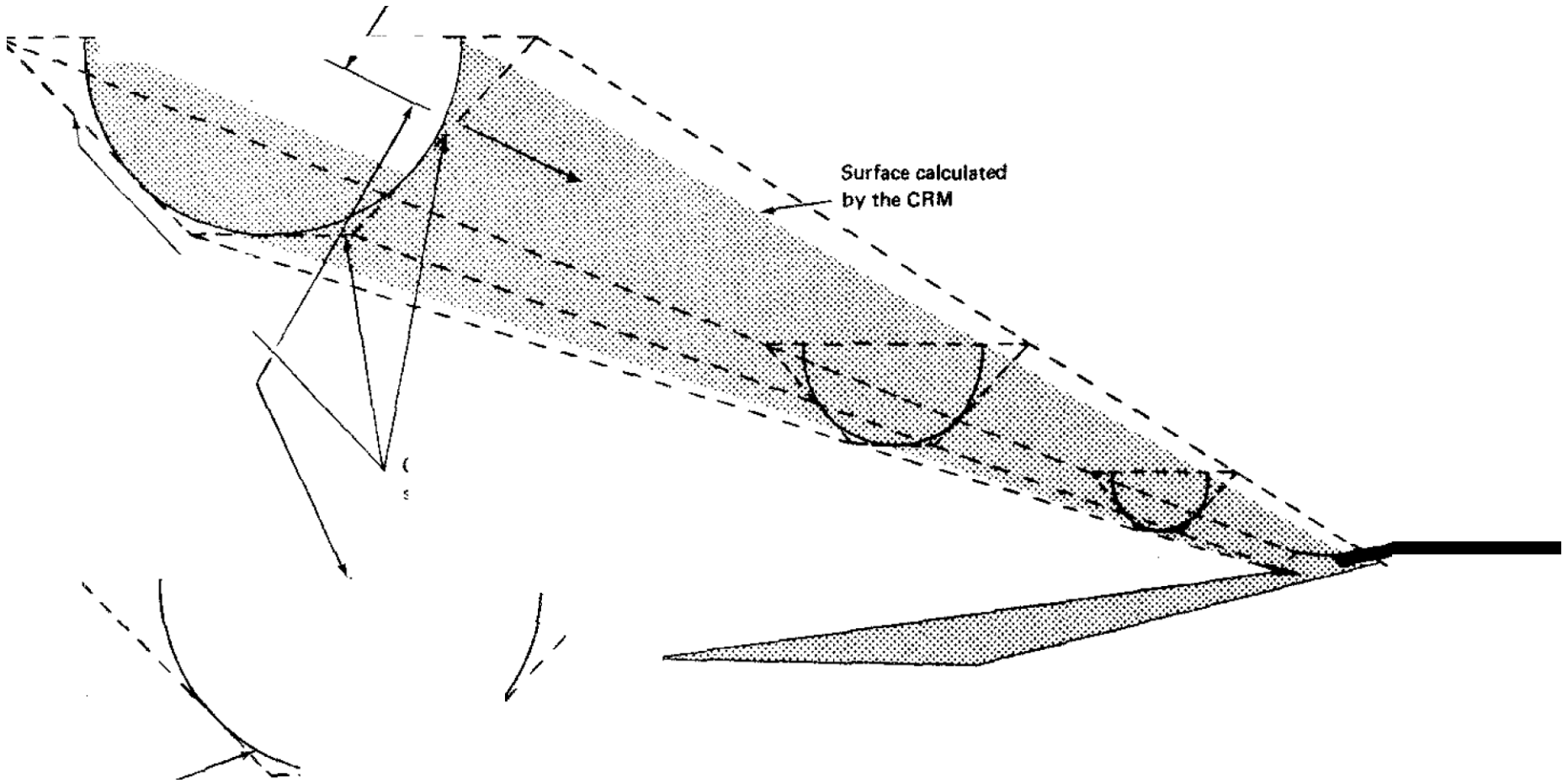

1.5. BACKGROUND OF THE COLLISION RISK MODEL

1.5.1 The Collision Risk Model (CRM) is a computer programme that calculates the probability of collision with obstacles by an aeroplane on an ILS approach and subsequent missed approach. The CRM was developed by the Obstacle Clearance Panel as a result of an extensive data collection programme followed by detailed mathematical analysis. The CRM is an important part of the criteria for ILS operations described in Part III of the PANS-OPS, Volume II.

1.5.2 Obstacle assessment and obstacle clearance calculations can be carried out by using obstacle assessment surfaces (see 13.3 above). However, this manual method, although simple in concept, involves tedious numerical calculations and is thus time-consuming, particularly if the number of obstacles is high. Furthermore, it suffers from two main drawbacks:

a) Firstly, the requirement that the OAS be of simple form (a set of plane surfaces) to allow easy manual application of the criteria, results in the surfaces being overprotective in certain areas, particularly in the vicinity of the runway. This is precisely the area where critical obstacles (glide path antenna, holding aircraft, etc.) are most likely to be sited. Hence, under the OAS criteria, such obstacles may unnecessarily prevent aeroplanes operating to low minima.

b) Secondly, the use of the OAS implies that these surfaces could become solid walls without any operational penalty in terms of an increase in OCA/H. Clearly such a situation would degrade safety. If left entirely to the operational judgement of the procedures specialist to decide at what point there exists an excessive density of obstacles around the runway, an insufficient operational penalty could result.

1.5.3 Therefore, although the OAS criteria are designed to achieve a specified target level of safety, they may be most likely to be sited as a result in a greater level of safety being imposed and consequently unnecessarily prevent operations to low minima or, alternatively, they may result in the safety of operations being degraded below the required standards. The CRM has been developed in response to these problems. It will:

a) provide risk computations (separately for all obstacles and for individual obstacles) to a specific set of conditions and runway environment: and

b) provide minimum acceptable OCA/H values for a specific set of conditions and

runway environment.

1.5.4 The CRM may also be used to assist:

- a) in aerodrome planning (in evaluating possible locations for new runways in a given geographical and obstacle environment);
- b) in deciding whether or not an existing object should be removed; and
- c) in deciding whether or not a particular new construction would result in an operational penalty (Le. in an increase in OCA/H).

1.5.5 Doc 9274-AN/904, entitled Manual on the Use of the Collision Risk Model (CRM) for /LS Operations, provides a comprehensive description of the CRM and instructions for its use.

Chapter 2

CONTROLLING OBSTACLES AT AN AIRPORT

2.1. BACKGROUND

2.1.1. In the early days of aviation, the rights of property owners were considered to extend from the surface downward to the center of the earth and upward to infinity. Accordingly, the owner was free to erect structures on his land to unlimited heights and any encroachment in the airspace by others constituted a trespass. This meant that aircraft could not fly over private property at any altitude without permission of each property owner. Obviously, that policy could have prevented the development of civil aviation and scheduled air transportation. Gradually, courts and legislatures have modified the ownership doctrine to specify that a property owner has exclusive rights to the airspace over his land only to the greatest height which he might reasonably be expected to use, with a right of free public transit through the air above such height.

2.1.2 When buildings encroach on the airspace needed for aircraft operations, a conflict of interest arises between property owners and airport operators. If such differences cannot be resolved, it may be necessary for the national authority charged with approving aircraft operating procedures to establish restrictions limiting operations in the interest of safety. Such restrictions might take the form of requiring displaced thresholds (resulting in a reduction in effective runway length), higher weather minima for operations, reductions in authorized aircraft masses and possibly restriction of certain aircraft types. Any of these actions could seriously affect orderly and efficient air transportation to an airport and adversely affect the economy of the communities served by the airport.

2.1.3 Control of obstacles in the vicinity of airports is, therefore, a matter of interest and concern to national governments, local communities, property owners and airport operators. There are severe legal, economic, social and political limitations to what can be achieved by any of these interests with respect to an existing airport where obstacles already exist. Even in the ideal situation of developing a new airport in an open area with no obstacles, prevention of future obstacles may be difficult because historically airports have expanded towards neighboring communities and, conversely, communities have grown towards the airport boundaries. Every effort should be exerted by all interested parties to prevent erection of future obstacles and to remove or lower existing obstacles.

2.2 LEGAL AUTHORITY AND RESPONSIBILITY

2.2.1 National governments generally have the basic authority and primary responsibility to establish criteria for the limitation of obstacles and to provide guidance and assistance to those directly concerned with control of obstacles. These criteria should take the form of the obstacle limitation surfaces set forth in Chapter 1, and should be compatible with those in MAS 1, Chapter 4. In addition, national authorities should make clear to community and airport officials the social and economic problems which may result from failure to maintain obstacle limitation surfaces free from obstacles.

2.2.2 In addition to setting criteria, government agencies should, where feasible or necessary, authorize local community officials to adopt zoning regulations to limit heights of buildings and trees to minimize future penetrations of obstacle limitation surfaces. Also, governments should authorize airport operators (or local communities) to acquire air easements or property rights (where such authority does not already exist), including the power to condemn property in the public interest by the exercise of eminent domain. Governments may also adopt rules and regulations designed to ensure notification of possible future obstacles in the interest of safety of aircraft operations.

2.2.3 Local community bodies such as municipal or county administrations, planning agencies and construction licensing authorities should, when properly authorized, adopt height zoning regulations based on appropriate obstacle limitation surfaces, and limit future developments accordingly. They may require property owners or developers to give formal notice of any proposed structure which may penetrate an obstacle limitation surface. Local bodies should co-operate closely with airport operators to ensure that the measures taken provide the greatest possible degree of safety and efficiency for aircraft operations, the maximum economic benefits to neighbouring communities and the least possible interference with the rights of property owners.

2.2.4 Ultimate responsibility for limitation and control of obstacles must, in practice, rest with the airport operator. This includes the responsibility for controlling obstacles on airport property and for arranging the removal or lowering of existing obstacles outside the airport boundaries. The latter obligation can be met by negotiations leading to purchase or condemnation {where authorized} of air easements or title to the property.

2.2.5 Each airport manager should designate a member of his staff to be responsible for the continuing process of making sure that airport approach, departure and manoeuvring areas remain clear of obstacles which may jeopardize safety. The airport manager, or his designee, should work closely with government agencies at all levels, national and local, to ensure that all possible steps have been taken to prevent erection of obstacles, including providing information to zoning authorities on the location, length, orientation and elevation of runways on which obstacle limitation surfaces are based. The airport manager must maintain constant vigilance to prevent erection of obstacles around his airport and he should alert other agencies to potential problems which may arise under their jurisdiction. In order to fulfil these obligations, the airport manager should establish a programme of regular and frequent visual inspections of all areas around the airport in order to be sure that any construction activity or natural growth (i.e. trees) likely to infringe any of the obstacle limitation surfaces is discovered before it may become a problem. This inspection programme should also include a daily observation of all obstacle lights, both on and off the airport, and corrective action in the case of light failure.

2.2.6 In summary, once the national government has set forth the necessary criteria, the principal methods of controlling obstacles available to community authorities and airport operators are height zoning, purchase of easements and purchase of property. Each of these issues is dealt with in greater detail in the following paragraphs.

2.3 HEIGHT ZONING

2.3.1 Enactment of zoning regulations incorporating height limits related to airport obstacle limitation surfaces is a difficult and complex process but a necessary one. A Model Zoning Ordinance to achieve this objective, is presented in Appendix 2. As a general rule, any community desiring to adopt such an ordinance will need legal authority to do so from a higher level of government. Even when so authorized, the effectiveness of height zoning as a means of protecting airports may be severely limited.

2.3.2 It has become a well-established principle of law that zoning cannot be so restrictive as to deprive a property owner of his right to the use of his property without adequate compensation. Many height zoning ordinances have been ruled invalid by the courts when property owners have claimed invasion of their property rights.

2.3.3 Such considerations limit the effectiveness of height zoning, particularly in the most critical areas close to runway ends, where obstacle limitation surfaces may require very low heights. Any height zoning must recognize this fact and provide for a minimum allowable height which is reasonable in terms of existing land use in the vicinity. Even so, local opposition to aircraft operations and to any form of restrictions on use of property may give rise to legal challenges leading to possible invalidation of any but the most carefully drafted zoning ordinance.

2.3.4 Height zoning, and indeed any form of zoning, cannot be made retroactive. Existing structures and trees which do not conform to the zoning limits are generally permitted to continue as non-conforming uses. Obstacles of this nature must be dealt with by other methods, such as purchase of easements or property rights.

2.3.5 The fact that obstacle limitation surfaces for a single airport may overlie the property of several independent communities or legal jurisdiction further complicates the problem of adopting effective zoning. Airport operators have no zoning powers, and must rely on the co-operation of neighboring communities. This may involve as many as thirty or forty separate jurisdictions, some of which may be unco-operative. In some cases, higher governmental bodies have authorized the creation of regional planning groups with the power to adopt uniform zoning standards. For example, in one such instance, a state government has authorized establishment of joint airport zoning boards with membership from the airport operator and each surrounding municipality. The board is empowered to adopt land use restrictions within 3.2 km of the airport boundary under approach areas, and 1.6 km elsewhere. The board may also enact height-restriction zoning within 1.6 and 2.4 km from the airport boundary.

2.3.6 As suggested by the above, land use zoning may also be helpful in certain areas as a means of preventing erection of obstacles. Where feasible, undeveloped areas may be zoned for uses which do not normally involve tall structures. Such uses may include agriculture, recreational activities, parks, cemeteries, auto parking and low (one-story) industrial buildings.

2.3.7 As outlined in Appendix 2, typical zoning ordinances generally include a statement of the purpose of or necessity for the action, a description of the obstacle limitation surfaces which should conform to the surfaces described in Chapter 1, and a statement of allowable heights which should conform to the specifications in MAS 1, Chapter 4. Provisions are also made for a minimum allowable height, for existing non-conforming uses, for marking and lighting of obstacles and for appeals from the provisions of the ordinance.

2.4 PURCHASE OF EASEMENTS AND PROPERTY RIGHTS

2.4.1 In those areas where zoning is inadequate, such as locations close to runway ends or where existing obstacles are present, the airport operator should take steps to protect the obstacle limitation surfaces. These steps should include removal or reduction in height of existing obstacles, as well as measures to ensure that no new obstacles may be erected in the future.

2.4.2 An airport authority could achieve these objectives either by purchase of easements or properly rights. Of these two alternatives, the purchase of easements would often prove to be more simple and economical. In this case, the airport authority secures the consent of the owner (after paying suitable compensation) to lower the height of the obstacle in question. This may be done by direct negotiation with the property owner. Such an agreement should also include provision to prevent erection of future obstacles, if height zoning limits are not in effect or are inadequate to protect obstacle limitation surfaces.

2.4.3 Where negotiations to obtain easements are not successful, then the airport operator should give consideration to the second alternative, i.e. purchase of the property. The airport operator could resort to the acquisition of the property by condemnation if the government has authorized such action. In such cases, the airport operator must pay a reasonable compensation to the property owner, i.e. at the fair market value of the property.

2.4.4 One major airport operator has been specifically authorized to use the power of condemnation for obstacle clearance to a maximum distance of 4.8 km from the ends of the runways. Condemnation of property for the purpose of installing navigational aids is also authorized, but without the restriction as to distance.

2.4.5 Purchase of property rights involves several obstacles. If the property to be acquired would be removed from the tax rolls, as is often the case when the airport is publicly owned, the community official and the airport neighbors may oppose the action because of the added tax burden on other properties. Also, neighbours of the affected property may object to acquisition by the airport for a number of reasons. Ownership of property which is not needed for airport purposes may be a burden to the airport operator because of the added expense of maintaining the property.

2.4.6 The tax exemption problem could be met by agreement to pay a sum in lieu of taxes, but this could be an extra expense to the airport operator for property which is not really needed. A better solution, where feasible, would be to sell the bulk of the property to private owner's subject to protective covenant designed to prevent

creation of future obstacles. Resale of property would, of course, have to be consistent with applicable zoning in the area. Beyond a distance of about 300m from a runway end and land needed for approach lighting systems or other navigational aids, the airport operator should be able to sell most other land subject to appropriate height and use restrictions. Such sales would help to recover a substantial part of the cost of acquisition, would eliminate the continuing cost of maintenance and would return the land to the tax rolls. Appropriate use restrictions would include those mentioned in Section 2.1 above, if such uses are authorized by zoning regulations and acceptable to the community.

2.5 NOTIFICATION OF PROPOSED CONSTRUCTION

2.5.1 One of the difficult aspects of obstacle control is the problem of anticipating new construction which may penetrate obstacle limitation surfaces. Airport operators have no direct means of preventing such developments. As noted above, they should conduct frequent inspections of the airport environs to learn of any such projects. Although there is no legal obligation for airport operators to report proposed construction when they become aware of it, their own self-interest and the need to protect the airport indicate the wisdom of bringing such matters to the attention of the appropriate authorities. Of course, where an obstacle is to be located on airport property, such as electronic or visual aids, the airport operator is responsible for reporting such projects.

2.5.2 Several countries have enacted legislation or adopted regulations designed to assign responsibility for reporting new construction projects. The obligation to report such construction may rest with local agencies such as planning bodies or construction licensing authorities or with the developer himself. In some cases, height limits have been specified; these are generally consistent with the criteria of Annex 14, Chapter 4, below which local authorities may authorize a project without higher review. If any part of a proposed development appears to penetrate an obstacle limitation surface, then the project should be referred to the appropriate civil aviation authority for review. This review would examine the effect of the envisaged construction on air navigation in general and on operational procedures in use in particular. If the conclusion of the above study is that the proposed construction can be permitted under some conditions, these should also be identified, e.g. display of obstacle marking and lighting, compliance with other appropriate measures for continued safety of air navigation, etc. Finally, all concerned should be notified of the new construction through charts (in accordance with Annex 4 - Aeronautical Charts, and through Notices to Airmen (NOTAM) or Aeronautical Information Publications (AIP) pursuant to Annex 15.

2.5.3 Among other States, the Federal Republic of Germany, the United Kingdom and the United States have established procedures for reporting proposed construction. Highlights of such procedures (in effect as of the indicated dates) are summarized for information.

a) Federal Republic of Germany (FRG) - Aeronautical Act (Amended 8 January 1961)

Articles 12 through 19 deal with control of construction in the vicinity of licensed airports. The provisions of these articles specify that the authority competent for granting construction licenses may license the construction of buildings only with the consent of the aeronautics authorities when construction is within a radius of 1.5 km from the airport reference point (see Section 2.6 below) or on the take-off, landing and safety areas. Consent of the aeronautics authorities is also required if construction is intended to exceed specified height limits within various larger radii from the airport reference point, or within specified distances within the approach zones.

b) United Kingdom (UK) - CAP 168 "Licensing of Aerodromes", December 1978, Chapter 4 - The Assessment and Treatment of Obstacles

Section 1 I specifies that, under the Town and Country Planning (Aerodromes) Direction 1972, the Civil Aviation Authority safeguards certain important aerodrome against future developments which might prejudice their actual or potential use for flying purpose:., A safeguarding map is deposited with the local planning authority, showing the height above which new construction near an aerodrome may interfere with its use. The planning authority is required to consult the Civil Aviation Authority about any development exceeding the appropriate reference level. If a licensee (airport operator) become aware of a proposed development which in his opinion infringes any criterion or would inhibit intended development of the aerodrome, he should request the planning authority to take this into consideration in determining the application.

c) United States (US) - Federal Aviation Regulations, Part 77 (Amended 4 March 1972)

Section 77.11 requires each person proposing specified kinds of construction or alteration to give "adequate notice" to the Administrator of the Federal Aviation Administration (FAA) together with supplemental notices 48 hours before the start and upon completion. Section 77. 13 requires sponsors to notify the Administrator of any construction or alteration of more than 200 ft above ground level at its site,

or of greater height than an imaginary surface extending outward and upward at a slope of 100 to 1 for a horizontal distance of 20 000 ft from the nearest point of the nearest runway at any public airport having at least one runway more than 3 200 ft in length. Steeper slopes are specified for airports, with shorter runway and for heliports. Notice is also required for certain highway and rail construction, certain construction in an instrument approach area and construction of certain airports, in which case the "sponsor" would obviously be the airport operator. The FAA has also issued an Advisory Circular (AC 70/7460-20, 30 November 1977) describing and illustrating for construction sponsors the requirements and procedures for submitting a notice of proposed construction.

2.6 ESTABLISHMENT OF OBSTACLE LIMITATION SURFACES

2.6.1 The following obstacle limitation surfaces are essential elements of a height zoning regulation associated with a precision approach runway:

- a) conical surface;
- b) inner horizontal surface;
- c) approach surface;
- d) transitional surfaces; and
- e) balked landing surface.

Of these surfaces, only the balked landing surface does not form part of the height zoning regulations for non- instrument and non-precision approach runways. In the case of take-off runways, the only surface which affects the height zoning regulation is the take-off climb surface. The dimensions and slopes of all of the above-mentioned surfaces are specified in MAS 1, Tables 4-1 and 4-2, and a brief description of the surfaces also appears in Chapter 1 of this Manual.

2.6.2 The government agency responsible for civil aviation should establish obstacle limitation surfaces consistent with those defined in MAS 1. Airport operators should provide government agencies and local planning bodies (for use in developing height zoning limits) with pertinent information about each airport, including:

- a) location, orientation, length and elevation of all runways;
- b) locations and elevations of all reference points used in establishing obstacle limitation surfaces;

c) proposed categories of runway use - non-instrument, non-precision approach or precision approach (category I, II or III);

d) plans for future runway extension or change in category.

2.6.3 It would be desirable to base all obstacle limitation surfaces on the most critical airport design features anticipated for future development, since it is always easier to relax a strict standard than to increase the requirements of a lesser standard if plans are changed. Some major airports make a practice of attempting to protect all runways to the standards required for category III precision approaches, to maintain maximum flexibility for future development.

2.6.4 *Aerodrome reference point.* MAS 1 calls for the establishment of an aerodrome reference point to be used as the designated geographical location of the aerodrome. This reference point should be located near the geometric centre of the aerodrome. Locations of aerodrome reference points should be measured and reported to the nearest second of latitude and longitude. These figures may also be converted into terms of local grid systems for the convenience of community authorities concerned with zoning or limitation of construction. Elevations of reference points should be measured and reported to the nearest metre above a specified datum, such as mean sea level.

2.6.5 *Inner horizontal surface.* Although MAS 1 does not specify a point of origin for the inner horizontal surface, a common use has evolved in several major aeronautical States. Originally, the inner horizontal surface was defined as a circle with its centre at the airport reference point. As airports grew larger and runway patterns became more complex, this circle proved inadequate and efforts were made to describe a larger surface by designating a secondary reference point and constructing an elliptical surface based on the two reference points as foci. More recently, it has been found preferable to designate a reference point at r near each runway end. These reference points are usually located at the end of the runway strip (60m from the runway end where the runway code number is 3 or 4) and on the extended runway centre line. The inner horizontal surface is then constructed by striking an arc of the proper radius from each such reference point. The boundary of the surface is completed by straight lines tangent to adjacent arcs. Such a surface is illustrated in chapter 1, Figure 1-2. The conical surface originates from the periphery of the surface so constructed. Where significant differences exist between runway end elevations (of the order of 6 m or more), it would be desirable to establish the elevation of the inner horizontal surface 45 m above the lowest reference point elevation to provide a greater margin of safety.

2.7 OBSTACLE SURVEYS

2.7.1 Identification of obstacles requires a complete engineering survey of all areas underlying the obstacle limitation surfaces. Such surveys are generally conducted by governmental authorities with the co-operation of the airport operator (see Chapter 4 of this manual). In the absence of a governmental survey, the airport operator should consider making the necessary survey with his own staff or with the assistance of a consultant or local operators.

2.7.2 *Initial survey.* The initial survey should produce a chart presenting a plan view of the entire airport and its environs to the outer limit of the conical surface (and the outer horizontal surface where established), together with profile views of all obstacle limitation surfaces. Each obstacle should be identified in both plan and profile with its description and height above the datum, which should be specified on the chart. More detailed requirements are contained in Chapters 3 and 4 of Annex 4, describing Aerodrome Obstruction Charts. Engineering field surveys may be supplemented by aerial photographs and photogrammetry to identify possible obstacles not readily visible from the airport.

2.7.3 *Periodic surveys.* The airport operator should, as previously suggested, make frequent visual observations of surrounding areas to determine the presence of new obstacles. Follow-up surveys should be conducted whenever significant changes occur. A detailed survey of a specific area may be necessary when the initial survey indicates the presence of obstacles for which a removal programme is contemplated. Following completion of an obstacle removal programme, the area should be re-surveyed to provide corrected data on the presence or absence of obstacles. Similarly, revision surveys should be made if changes are made (or planned) in airport characteristics such as runway length, elevation or orientation. No firm rule can be set down for the frequency of periodic surveys, but constant vigilance is required. Changes in obstacle data arising from such surveys should be reported to the aviation community in accordance with the provisions of Annex 15- Aeronautical Information Services.

2.8 REMOVAL OF OBSTACLES

2.8.1 When obstacles have been identified, the airport operator, with the assistance of local community agencies, should make every effort to have them removed or reduced in height so that they no longer constitute an obstacle. This will require negotiation with be possible to reach agreement to reduce the height to acceptable limits without adverse effect. In other cases, such as a building, it may be necessary to arrange for removal of the entire structure. This will, in all probability, require

purchase or condemnation of the property. In either case, the airport operator must be prepared to compensate the property owner for any loss of value.

2.8.2 Where agreement can be reached for the reduction in height of an existing obstacle, the agreement should include a written aviation easement limiting future heights over the property to specific levels which conform to the pertinent obstacle limitation surfaces, unless effective height zoning has been established (see Sections 2.3 and 2.4 above).

2.8.3 *Trees*. In the case of trees which are trimmed, agreement should be reached in writing with the property owner to ensure that future growth will not create new obstacles. Property owners can give such assurance by agreeing to trim trees when necessary or by permitting access to the premises for the purpose of having such trimming done by representatives of the airport operator.

2.8.4 Some aids to navigation, both electronic (such as ILS components) and visual (such as approach and runway lights), constitute obstacles which cannot be removed. Such objects should be frangibly designed and constructed, and mounted on frangible couplings so that they will fail on impact without damage to an aircraft. Guidance on the frangibility requirements of visual and non-visual aids to navigation is contained in Chapter 5 of this manual. Where necessary, such objects should be marked and/or lighted.

2.9 SHIELDING

2.9.1 In many countries the principle of shielding is employed to permit a more logical approach to restricting new construction and prescribing obstacle marking and lighting. It also reduces the number of cases of new construction requiring review by authorities. Shielding principles are employed when some object, an existing building or natural terrain, already penetrates above one of the obstacle limitation surfaces described in MAS 1. If it is considered that the nature of an object is such that its presence may be described as permanent, then additional objects within a specified area around it may be permitted to penetrate the surface without being considered as obstacles. The original obstacle is considered as dominating or shielding the surrounding area.

2.9.2 The Seventh Session of the AGA Division introduced the principle of shielding to MAS 1. Though the Division recognized the use of shielding in the specifications of MAS 1, it did not draft specifications concerning the details of its employment. The Division did discuss how shielding should be employed but decided to leave this material as guidance for the present time.

2.9.3 It was generally agreed that the formula for shielding should be based on a horizontal plane projected from the top of each obstacle away from the runway and a plane with a negative slope of 10 per cent towards the runway. Any object which is below either of the two planes would be considered shielded. The permission to allow objects to penetrate an obstacle limitation surface under the shielding principle should, however, be qualified by reference to the need for an aeronautical study in all cases.

2.9.4 The shielding effect of immovable obstacles laterally in approach and take-off climb areas is more uncertain. In certain circumstances, it may be advantageous to preserve existing unobstructed cross-section areas, particularly when the obstacle is close to the runway. This would guard against future changes in either approach or take-off climb area specifications or the adoption of a turned take-off procedure.

2.9.5 The permanency of the immovable obstacle which is to be considered as shielding an area should be given very careful review. An object should be classed as immovable only if, when taking the longest view possible, there is no prospect of removal being practicable, possible or justifiable, regardless of how the pattern, type or density of air' operations might change.

2.9.6 In use, the methods for determining the extent of area shielded by a permanent obstacle and permissible height limits around it vary between States. It has often been found difficult to apply firm policies on this matter, and generally an aeronautical study is carried out to review the exact effect the construction of a new object will have. Several States, notably Austria, Chile, Czechoslovakia, Egypt, the Lao People's Democratic Republic, the Kingdom of the Netherlands and Switzerland, have reported that they followed the guidance provided above. To give some guidance on alternative shielding concepts, the practices of several selected States are given in Appendix 3.

2.10 MARKING AND LIGHTING OF OBSTACLES

2.10.1 Where it is impractical to eliminate an obstacle, it should be appropriately marked and/or lighted so as to be clearly visible to pilots in all weather and visibility conditions. MAS 1, Chapter 6 contains detailed requirements concerning marking and/or lighting of obstacles. Some guidance on the characteristics of high intensity obstacle lights is included in the GM 2.4, Visual Aids.

2.10.2 It should be noted that the marking and lighting of obstacles is intended to reduce hazards to aircraft by indicating the presence of obstacles. It does not necessarily reduce operating limitations which may be imposed by the obstacle.

MAS 1 specifies that obstacles be marked and, if the airport is used at night, lighted, except that:

- a) such marking and lighting may be omitted when the obstacle is shielded by another fixed obstacle; and
- b) the marking may be omitted when the obstacle is lighted by high intensity obstacle light by day.

Vehicles and other mobile objects, excluding aircraft, on movement area of airports should be marked and lighted, unless used only on apron areas.

2.10.3 Installation and maintenance of required marking and lighting may be done by the property owner, by community authorities or by the airport operator. The airport operator should make a daily visual inspection of all obstacle lights on and around the airport, and take steps to have inoperative lights repaired. In some cases, principally at commercial or industrial sites, the property owner may provide for maintenance, repair and replacement of lights. Otherwise, the airport operator should have agreements permitting his representatives to enter the property and perform the necessary maintenance. Many airport operators have found it helpful to use dual light fixtures with an automatic switch to the second light fixture if the first one fails. Such an arrangement provides greater assurance of continued obstacle lighting and reduces the number of visits to replace inoperative lamps.

2.11 REPORTING OF OBSTACLES

2.11.1 MAS 1, Chapter 2 specifies that the location, top elevation and type of each significant obstacle on or in the vicinity of an aerodrome shall be made available. Specifications concerning the services to which the above details are to be made available and the manner in which they are to be published are prescribed in Annexes 4 and 15. From the standpoint of safety and regularity of civil aviation, every effort should be made to comply with the above requirements.

2.11.2 Whenever an obstacle, either temporary or permanent in nature, is identified, it should be reported promptly to the aviation community. To this end, the agency conducting the obstacle survey (government or airport operator) should be responsible for seeing that information on obstacle is promptly transmitted to the authority responsible for disseminating aeronautical information, viz. aeronautical information service. As indicated in Section 2.5, reporting of new construction may be done by the project sponsor, the local planning body, the construction licensing authority or the airport operator. The airport operator has the most direct interest in seeing that information is properly disseminated and, through visual inspections and

periodic surveys, is most likely to be aware of the presence of new obstacles. It is, therefore, in his best interest for the airport operator to report all data on obstacles, including marking and lighting, to the aeronautical information service for further distribution. Reports may be verbal, but should be confirmed in writing as soon as possible.

2.11.3 Annex 15 contains detailed requirements on methods of disseminating aeronautical information, including data on obstacles. In addition to NOTAM, which may be given either Class I distribution (by means of telecommunication) or Class II (by other means), material may be issued in the form of Aeronautical Information Publications (AIPs) or Aeronautical Information Circulars. Where a critical situation may exist, information should be disseminated by verbal reports from the air traffic control to aircraft in the vicinity. AIPs should contain (among other items) current information on obstacles and obstacle marking and lighting. Each AIP should be amended or reissued at regular intervals as may be necessary to keep it up to date.

2.11.4 Obstacle information from obstacle surveys or other sources, such as reports from airport operators, is also presented in the form of Aerodrome Obstruction Charts A and B, Instrument Approach Charts, Visual Approach Charts and Landing Charts, which are described in Chapters 3, 4, 8, 11 and 12 of MAS 1. Charts produced in conformity with the provisions of Annex 4 may form a part of the AIP, or may be distributed separately to recipients of the AIP.

2.11.5 A high degree of co-operation among government and local authorities, airport operators and property owners is required to control obstacles and to provide a safe environment for efficient operation of aircraft at airports.

Chapter 3

TEMPORARY HAZARDS

PREFERRED PROCEDURE FOR DEALING WITH TEMPORARY HAZARDS ON RUNWAY STRIPS

3.1 INTRODUCTION

3.1.1 The term "temporary hazard" includes work in progress at the sides or ends of a runway in connexion with airport construction or maintenance. It also includes the plant, machinery and material arising from such work and aircraft immobilized near runways.

3.1.2 The prime responsibility for determining the degree of hazard and the extent of tolerable obstacle must ultimately rest with the competent authority who should take into account:

a) runway width available;

b) types of aircraft using the airport and distribution of traffic;

c) whether or not alternative runways are available;

a) the possibility of cross-wind operations, bearing in mind seasonal wind variations;

b) the weather conditions likely to prevail at the time, such as the visibility and precipitation. The latter is significant as it adversely affects the braking coefficient of the runway, and thus an aircraft's controllability during ground run;

f) the possibility of a compromise between a reduction in runway length and some degree of the approach surface infringement.

3.1.3 All such hazards should be promulgated by NOTAM and marked and lighted in accordance with the requirements of MAS 1. For unforeseeable hazards, such as aircraft running off runways, pilots must be informed by Air Traffic Control of the position and nature of the hazard.

3.2 RESTRICTIONS FOR NON - INSTRUMENT AND ON - PRECISION APPROACH RUNWAYS

3.2.1 Three zones alongside runways can be identified and are shown on Figure 3-1 as I, II and III.

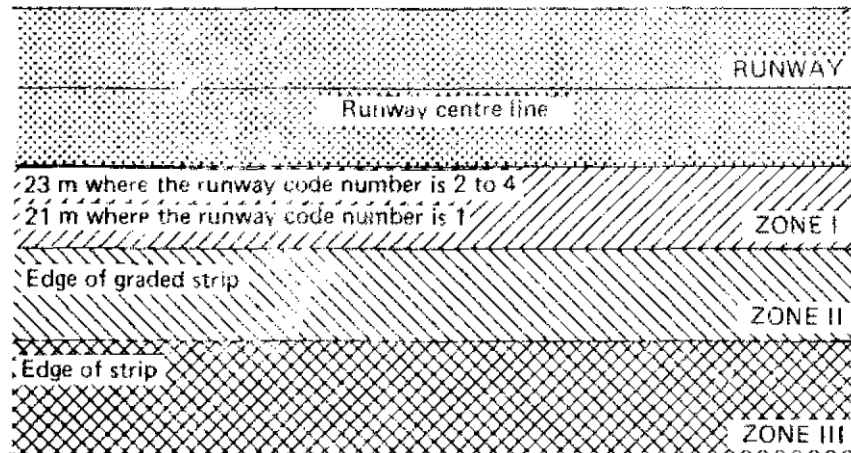

Figure 3-1. Limits of zones

Zone I

3.2.2 This zone lies within:

- 23 m of the runway edge where the runway code number is 2, 3 or 4;
- 21 m of the runway edge where the runway code number is 1.

3.2.3 Work may take place in this zone on only one side of the runway at a time. The area of the obstacle should not exceed 9m², but narrow trenches may exceptionally be allowed up to 28m². Any obstacle permitted should be limited in height to provide propeller or pod clearance for the type of aircraft using the

aerodrome, and in no case should the height exceed 1m above the ground. Any piles of earth or debris which could damage aircraft or engines must be removed. Trenches and other excavations should be backfilled and compacted as soon as possible.

3.2.4 No plant or vehicles should operate in this zone when the runway is in use.

3.2.5 An aircraft immobilized in this zone would automatically require the closure of the runway.

Zone II

3.2.6 This zone extends from the outer edge of Zone I to the edge of the graded strip for each class of runway.

3.2.7 The restrictions to be applied depend on the type of operation taking place and the weather conditions.

3.2.8 With a dry runway and not more than 15 kt cross-wind component for runways of code number 4, and 10 kt cross-wind component for runways of code number 2 or 3, the following work may be permitted:

a) Visual flight conditions

1) Unrestricted areas of construction, with the length of excavation or excavated material parallel to the runway being kept to a minimum. The overall height of excavated material shall be limited to 2 m above the ground.

2) All construction equipment should be mobile and kept within normal height limits.

3) The runway may continue in use when an aircraft is immobilized in this zone.

b) Instrument flight conditions

1) Unrestricted areas of construction, with the length of excavation or excavated material parallel to the runway being kept to a minimum. The overall height of excavated material shall be limited to 2 m above the ground.

2) All construction equipment should be mobile and kept within normal height limits.

3) When an aircraft becomes immobilized in this zone, the runway should be closed.

Zone III

3.2.9 This zone applies only to non-precision approach runways used in conditions of poor visibility or low cloud base. It extends outwards from the edge

of the graded strip to the edge of the strip required for missed approaches, i.e. 1 50 m from the runway centre line.

3.2.10 There are no restrictions on the work in this area. However, care must be taken to ensure that the work and the vehicles associated with the work do not interfere with the operation of radio navigational aids. The critical zones for radio aids are described in Annex 10, Attachment C.

Note. - Contractor's permanent and semi-permanent plant and mobile equipment withdrawn from the strips should not infringe the transitional surfaces described in MAS 1.

Runway ends

3.2.11 In the case of work adjacent to the runway ends, the maximum possible use should be made of alternate runways or the displacement of the threshold so that the obstacle does not fall within the effective strip length or penetrate the associated approach surfaces. However, where landing distance may be critical, it may be safer to permit such an infringement near the runway end rather than displace the threshold.

3.3 RESTRICTIONS FOR PRECISION APPROACH RUNWAYS

3.3.1 Precision approach runways category III. ICAO Circular 148, entitled Surface Movement Guidance and Control Systems, details what special procedures should be followed to ensure safety when operations are taking place under low visibility conditions. The restrictions concerning the movement of vehicles and personnel detailed therein should be observed. In particular, no work should be permitted on any part of the movement area when the runway is being used. All equipment should be outside the obstacle-free zone and all personnel should be withdrawn from the movement area. The restrictions concerning the height of piles and debris in 3.2.3 and 3.2.8 are equally applicable to precision approach runways category III.

3.3.2 Precision approach runways category I and II. No work should be permitted within the OFZ when the runway is in use. All equipment and personnel should be outside the obstacle-free zone. The restrictions concerning the height of piles and debris in 3.2.3 and 3.2.8 are equally applicable to these runways.

3.4 PRE-CONSTRUCTION MEETING

3.4.1 It is an excellent practice for the contractor, airport operator and traffic control authority (where traffic control exists) to meet well in advance of the start of construction. This meeting can then consider such matters as discussed above, and agree on:

- a) means of control of construction vehicles so as to minimize interference with aircraft operations;
- b) scheduling of construction activities to conform as much as possible to periods of minimum aircraft activity;
- c) disposal of excavated material, storage of construction materials and equipment, and conditions of work site at the end of the period of work.

Chapter 4
OBSTACLE SURVEYS
4.1 AUSTRALIAN PRACTICE

4.1.1 This section deals with the survey of the approach area and surface, take-off climb area and surface, transitional, horizontal and conical surfaces at both proposed and existing airports, for the determination of the location and elevation of objects that may constitute infringements of these surfaces. In the case of a precision approach runway or a runway on which a precision approach aid is likely to be installed, the survey should cover the additional horizontal surface associated with this aid. This horizontal surface, which is located 30 m above the aerodrome reference point, is rectangular in shape. The width of this surface is 1.75 km symmetrically situated about the runway centre line, and its length extends from a distance of 1050 m prior to the precision approach threshold to the end of the runway strip remote from this threshold.

4.1.2 Clearance surface¹ plans produced as a result of this survey, showing the aerial contours of the clearance surfaces in conjunction with the location and reduced level of objects which constitute obstacles, will enable:

- a) the assessment of the extent of infringement of the clearance surfaces and the practicability of reducing or removing the obstacles causing infringement;
- b) the determination of the extent to which marking of obstacles is necessary;
- c) the determination of operational procedures, such as critical heights for aircraft circling, and procedures for use in the event of an emergency during take-off and landing;
- d) the compilation of the height limitation plans associated with the Air Navigation (Buildings Control) Regulations. For the compilation of these plans it will be necessary for the clearance surface plans to include ground contours and features in critical areas. This information may be available from plans compiled by local government authorities, etc.; otherwise it will be necessary to obtain the information by normal survey methods.

4.1.3 The clearance surface survey should normally be carried out with a theodolite capable of reading both horizontal and vertical angles to at least 5".

¹ The term 'clearance surface' used in this section is synonymous with 'obstacle limitation surface'.

Clearance surface characteristics

4.1.4 The approach area and surface, the take-off climb area and surface and the transitional surface characteristics vary with the nature and type of aircraft operations conducted or proposed at the airport

4.1.5 Prior to commencing the survey, it is necessary to ascertain the nature and type of aircraft operations conducted or proposed at the airport, then determine the physical characteristics of the clearance surfaces.

4.1.6 If a topographical map of the area is available, the survey can be assisted materially by plotting the limits of the clearance surfaces on the map for use in the field.

Survey procedures

4.1.7 The survey procedure shall consist of determining:

- a) the location and reduced level of runway centre lines at the ends of existing and/or proposed runway strips, the ends of any approved clearway beyond the ends of the runway strips and, where future extension is contemplated, the ends of the future extension;
- b) the location and reduced level of the aerodrome reference point;
- c) the location and reduced level of the highest points of all objects which may constitute obstacles to the clearance surfaces. Ground levels should also be obtained for any obstacles which, in the opinion of the surveying officer, can be removed;
- d) the location and reduced level of the highest object between adjacent take-off climb areas within the horizontal and conical surfaces, irrespective of whether this object infringes the surfaces;
- e) the location and spot levels at changes in grade of any roads and railways within the approach area and less than 600 m from the inner end of this area;
- f) the magnetic bearing of the runway centre lines and the magnetic declination to the nearest degree.

4.1.8 Reduced levels should be determined to the nearest 0.30m and related to mean sea level if possible. If this is not possible, the assumed datum shall be clearly

indicated. Any procedure used for determining reduced levels must take account of the curvature of the earth and refraction as necessary to meet the order of accuracy as specified in 4.1.13.

4.1.9 Obstacles shall be designated, e.g. tree, hill, pole, tower, spire, vent, chimney, mast, post, antenna, building, house, etc.

4.1.10 The vertical and horizontal limits of penetration by obstacles of large extent, such as hills, mountain ranges, etc., shall be determined by obtaining critical spot reduced levels and the horizontal area of penetration.

4.1.11 The field work associated with 4.1.7 with the exception of c) and d), involves normal survey procedures and will not be dealt with further. In many cases this information is available from existing contour and feature plans.

4.1.12 The field work associated with 4.1.7 c) and d) involves, firstly, a preliminary procedure to identify objects which may constitute obstacles and, secondly, a procedure to determine the location and reduced level of these objects. In certain cases it may be possible to combine these two procedures.

Accuracy

4.1.13 The order of accuracy of the field work shall be such that the resulting data will be within the maximum deviations indicated hereunder:

a) the horizontal dimensions of runway strip ends, the ends of any approved clearway beyond the ends of the runway strips, ends of future extensions, shall be determined to the nearest 0.30 m;

b) objects which may constitute obstacles to the clearance surfaces shall be located horizontally within 4.5 m plus 0.30 m for every 150 m from the origin of the surface. Reduced levels shall be determined to within 23 cm in the first 300 m from the origin of the surface, increasing at the rate of 15 cm per 300 m thereafter.

Note. - For the purposes of accuracy the origin of the conical surface shall be the aerodrome reference point.

Take-off climb area and surface

4.1.14 An accurately measured baseline should be established at the end of the runway strip or at the end of any approved clearway beyond the end of the runway

strip. This baseline should be equal in length to the inner end of the take-off climb area, and it should be set out in such a manner that it is at right angles to and symmetrical about the runway strip centre line. Pegs should be established at the ends of this baseline, and these pegs should be coincident with the inner corners of the take off climb area. The reduced level of these pegs should be determined by normal levelling methods for later use in computing the reduced level of obstacles.

4.1.15 The outside edges of the take-off climb area should be established by positioning the theodolite on the corner pegs (ends of the baseline) and turning out a horizontal angle with reference to the baseline, equal to the splay angle plus 90° . Sighting poles positioned on the alignment of the outside edges, some distance from the corner pegs, will materially assist visual inspection of the extent of the take-off climb area.

4.1.16 With the theodolite set up over a corner peg, the take-off climb surface may be examined through the telescope of the instrument by setting out a vertical angle equal to the gradient of the surface and rotating the telescope from the outside edge of the area towards the extended centre line. This process is repeated from the opposite corner peg.

4.1.17 Any object that projects through the surface constitutes an obstacle, and as this method of identifying obstacles is not precise, any object closely approaching the surface should also be tentatively identified as an obstacle. This method of identifying obstacles is not precise due to the following factors:

- a) no correction is made for the instrument telescope being not coincident with ground level at the centre point of the inner edge of the surface;
- b) no correction is made for curvature and refraction;
- c) the gradient of the surface is not necessarily read in a vertical plane at right angles to the surface.

4.1.18 The location and reduced level of objects which constitute obstacles, or which have been tentatively identified as possible obstacles, may be determined accurately by:

- a) triangulation and the reading of vertical angles from the ends of the baseline or other control stations established for the purpose;

b) traverse and levelling from the baseline or other control stations. It would be necessary to employ this method where objects suspected of being obstacles are shielded by other obstacles.

4.1.19 As a general rule the principle of triangulation should not be employed where the apex angle (the angle at the object) is less than $2^{\circ} 15'$, or where the distance to the object is greater than 25 times the length of the baseline. For distant objects, this rule will entail lengthening the baseline by establishing other control stations or employing the principle of traversing or a combination of both traversing and triangulation.

4.1.20 In cases where future runway and/or strip extension is contemplated, the survey should be extended to include:

a) the location and reduced level of objects above ground level between the ends of the existing runway strip and the ends of the ultimate extension for the full width of the take-off climb area based on the end of the existing runway strip;

b) the location and reduced level of objects which constitute obstacles to a take-off climb surface from the end of the ultimate extension for the full width of the take-off climb area based on the end of the existing runway strip.

Approach area and surface

4.1.21 The physical characteristics of the approach area and surface are less critical than those of the take-off climb area and surface, except in the case of runways associated with precision approach landings.

4.1.22 The survey associated with the take-off climb area and surface will therefore fulfil the requirements of the approach area and surface except for the precision approach landing case.

4.1.23 The survey procedure for a precision approach area and surface is the same as set out for the take-off climb area and surface, except that the physical characteristics for an international or domestic precision approach area and surface (whichever is applicable) are used.

Transitional surface

4.1.24 The survey of the transitional surfaces, as far as identification of objects which constitute obstacles is concerned, can best be carried out in two parts. One part consists of the survey of the transitional surfaces associated with the approach

surface, and the second part, the survey of the transitional surfaces associated with the runway strip. The reference lines for the purpose of transitional surfaces associated with the runway strip are lines coincident with ground level originating at the ends of the inner edge of the approach areas drawn parallel to the runway centre line.

4.1.25 The identification survey for transitional surfaces associated with the approach surface can best be carried out with a theodolite or modified level⁽¹⁾ in which cross-hairs at a gradient of 1 in 7 have been incorporated.

4.1.26 For this part of the survey the instrument is positioned along the line representing the edge of the approach area and at such a distance outward along this line that the telescope is in the plane of the approach surface. The telescope is then elevated to the gradient of the approach surface, sighted along the 1:7 representing the edge and clamped both vertically and horizontally. The cross-hairs in the telescope at a gradient of 1 in 7 will then be in the plane of the transitional surface associated with the approach surface, and any objects which project through this plane constitute obstacles. The process is repeated for the opposite side of the approach surface.

4.1.27 If an instrument with cross-hairs at a gradient of 1 in 7 is not available, it is necessary to determine the location and reduced level of a number of objects suspected of being obstacles in the area under examination by precise methods such as those indicated in 4.1.18. Other objects can be compared with these by visual inspection, and the identification of possible obstacles can proceed.

(1) A modified level is a standard surveyor's level which has been especially modified for surveys of this nature. The modification consists of a rearrangement of the telescope optics to widen the field of view to permit the installation of a graticule on which percentage gradients have been engraved.

This enables the telescope bubble to be remained in the center of its run while the gradient is being read, and simplifies the instrument work to levelling the instrument, pointing and reading the percentage gradient direct. To facilitate the survey of transitional surfaces, lines at gradient of 1 in 7 have also been incorporated in the graticule.

4.1.28 The location and reduced level of objects which constitute obstacles, or which have been tentatively identified as possible obstacles, may be determined as indicated in 4.1.18.

4.1.29 For the identification survey of the transitional surface associated with the runway strip, the theodolite is positioned on a line Joining the object suspected of constituting an obstacle and the runway strip centre line (the line being at right angles to the strip centre line), and also at some distance outwards from the reference line (see 4.1.24), so that the telescope of the instrument is in the plane of the transitional surface.

4.1.30 The telescope is elevated to a gradient of 1 in 7 and clamped vertically, then sighted at the object. The telescope is then in the plane of the transitional surface and if the object projects through this plane it constitutes an obstacle.

4.1.31 When a number of objects have been treated similarly, other objects can be compared with these by visual inspection and the identification of possible obstacles can proceed.

4.1.32 The location and reduced level of objects which constitute obstacles, or which have been tentatively identified as possible obstacles, may be determined as indicated in 4.1.18

Horizontal and conical surfaces - Additional horizontal surface associated with a precision approach runway

4.1.33 The identification of objects which constitute obstacles to these clearance surfaces can best be carried out by reference to a topographical map on which the limits of the surfaces have been plotted. Since these objects will be at least 30 m above the aerodrome reference point, they will be tall, easily seen objects or objects on high ground, the location of which can be determined from an inspection of the topographical map.

4.1.34 If a topographical map is not available, it is necessary to determine the location and reduced level of a number of objects suspected of being obstacles to these surfaces by precise methods such as those indicated in 4.1.18. Other objects can be compared with these by visual inspection, and the identification of possible obstacles can proceed.

4.1.35 The location and reduced level of objects which constitute obstacles, or which have been tentatively identified as possible obstacles, may be determined as indicated in 4.1.18.

Application of aerial photogrammetry to clearance surface surveys

4.1.36 Where extensive and complex clearance surface surveys are involved, it may be expedient and economical to use the principle of aerial photogrammetry to produce a plan of the area showing the location and elevation of objects likely to constitute obstacles. On this plan the limits together with the aerial contour of the various clearance surfaces can be plotted, and the objectives as set out in 4.1.2 can be achieved.

Application of terrestrial photogrammetry to approach, take-off climb and transitional surface surveys

4.1.37 Where it is desired to produce a pictorial representation of the approach, take-off climb and transitional surfaces showing the extent of infringement of these surfaces, the method of taking terrestrial photographs described below may be employed. Such a pictorial representation is an ideal means of detailing requirements for approach, take-off climb and transitional surface clearing, particularly where the obstacles consist of heavily timbered areas. Such a pictorial representation is also an excellent check that all objects which constitute obstacles have been picked up by any previous survey using normal survey procedure.

Note. - The transitional surface referred to is the transitional surface associated with the approach surface only.

4.1.38 While it is possible to extend this photographic method to produce a plan showing the location and reduced level of obstacles, it has been found in practice that the additional photographs and field work required for this purpose make this aspect of the method too cumbersome.

Theory

4.1.39 If a camera is set up in a plane, the plane will project as a straight line on the negative. Further, if the camera is level and pointed in the direction of the steepest slope of the plane, the projection of the plane will be parallel to the projection of the horizontal plane through the camera.

4.1.40 Since the approach surface, take-off climb surface and transitional surface are planes, they will be projected on the negative as straight lines, provided the camera lens is in the plane under consideration when the photograph is taken.

4.1.41 In the case of a camera set on the edge of the splay, i.e. the intersection of the approach surface and the transitional surface, both planes will project on the negative as straight lines.

4.1.42 However, these planes cannot be drawn on the photograph unless they can be related to some datum available on the photograph. This datum can be supplied by setting out targets the reduced level of which is equal to that of the camera. A line drawn through these targets on the photograph will be the projection of the horizontal plane through the camera.

4.1.43 If the targets are set out so that the centre one is in the vertical plane through the axis of symmetry of the reduced plane and the others are set out on either side at a certain horizontal angle, it is possible to construct an angular scale from the three targets in the photograph.

4.1.44 Using this scale, distances can be set out on the photograph above the centre target equal to the angle of elevation of the surface under consideration. A line drawn through this point parallel to the horizontal plane would be the projection of the surface.

4.1.45 In the case of a camera set up on the edge of the splay and in the approach or take-off climb surface, targets are set as before, except that the outer target is set at an angle from the centre target equal to the angle of splay.

4.1.46 On the resultant photograph, the surface under consideration is drawn on to a point perpendicular to the outer target. At this point, in the case of the approach surface, a line at a 1 in 7 slope can be drawn towards the edge of the photograph, since we are looking across the slope of the transitional surface.

4.1.47 Since the bearing of any point on the photographs can be measured, it follows that the position of any object may be calculated or plotted, providing it appears in more than one photograph and the positions of the camera stations have been fixed by survey. However, as mentioned in 4.1.38, it has been found in practice that the additional photographs and field work required for this purpose make this aspect of the method too cumbersome.

Equipment

4.1.48 The camera should be a good quality camera with a 90 mm lens, or its equivalent.

4.1.49 The vertical control shall be established with a level similar to a Watts Microptic or its equivalent. The level shall have a small platform attached to the telescope barrel and the metal cover surrounding the main bubble. This platform forms a stable mount for the camera, and the weight of the camera is directly above the vertical axis of the level. Small ridges should be provided on the front and back

edges of the platform to hold the camera in the same position at each mounting. A captive screw should be provided on the camera tripod fitting. The horizontal control should be established with a theodolite.

4.1.50 Targets should be circular and consist of any rigid material with a tube and clamp screw on the rear side. They should be painted in quadrants, and should have a radius equal to the measurement between the axes of the telescope of the level and the camera.

4.1.51 The pole up and down which the target is adjusted for height may be the normal survey ranging rod, but should be capable of being extended to 3 to 3.5 m high.

Field procedure

4.1.52 Camera positions are selected on the extended centre line of the runway and on the outer edge of each splay, so that the camera, when set up, will in each case be in either the approach surface or the take-off climb surface. The camera in the splays, when associated with the approach surface, will also be in the transitional surface, since the outer edge of the splay is the intersection of the two planes. The camera positions are established, both in position and elevation, with respect to the end of the runway strip.

Note. - To obviate the necessity for two sets of photographs, one for the take-off climb surface and one for the approach and transitional surface. the transitional surfaces may be applied to the edges of the take-off climb surface rather than the edges of the approach surface in cases other than intentional precision approach surfaces. This may be done provided no significant economic penalty as regards clearing of transitional surfaces is involved.

4.1.53 When the camera position on the extended centre line is determined, the theodolite is set up over this point and target positions are established. One target is set on the extended centre line of the runway and one on each side at equal angles, selected to suit the camera - usually 20°. Targets need not be at any fixed distance from the camera.

4.1.54 The theodolite is replaced by the level and the bottom edges of the targets are levelled. The camera is then attached to the level. Since the radius of the target is equal to the vertical separation of the axes of the level telescope and the camera, the centres of the targets are level with the camera lens.

4.1.55 The camera is directed towards the centre target and the photograph taken.

4.1.56 A similar process is followed at the splay camera points. The centre target is set out on a bearing parallel to the extended centre line of the runway, the inner target 20° off this line, but the outer target is set out at the splay angle. The camera is directed at the centre target. It should be noted that the camera axis is always horizontal.

Office procedure

4.1.57 The resultant negatives are enlarged so that the 20° interval between targets measures 125 mm (this is approximately a four diameter enlargement).

4.1.58 A straight line drawn through the centre of the targets represents the horizontal plane through the camera.

4.1.59 Using a positive-negative transparent scale on which 20" equals 125 mm, a distance equal to the angle of elevation of the take-off climb or approach surface (whichever is applicable) may be marked up above the targets, and a line drawn parallel to the horizontal line through the targets. This line represents the required surface, and clearly indicates whether the surface is clear or obstructed.

4.1.60 With regard to the splay photographs, the surface can be similarly drawn, but is terminated immediately above the splay target. From here, a line at 1 in 7 is drawn outward, and this line represents the transitional surface.

4.1.61 The three photographs together represent a complete section of the take-off climb or approach and transitional surface.

4.2 UNITED KINGDOM PRACTICE

4.2.1 Aeronautical airport surveys are undertaken to determine the location and height of various objects in defined areas around an airport. This information is necessary for the production of aeronautical charts required for international aircraft operations, and for determining which of the objects constitute obstacles in the aeronautical sense. Those objects which are found to be obstacles can then be removed or, if this is not possible, they can be marked and/or lit.

4.2.2 The following airport survey specifications are used to obtain the obstacle data necessary to comply with the ICAO Standards and Recommended Practices contained in the relevant Annexes and the requirements in the United Kingdom document CAP 168 which deals with the physical requirements for United Kingdom licensed airports.

Type A obstruction chart survey

4.2.3 For runways used by large jet aircraft - The area to be surveyed commences at the inner edge of the take-off climb area, where it is 180 m wide. It is symmetrical about the extended centre line and increases uniformly in width from 180 m to 3 930 m at a distance of 15 000 m from origin. The significance of obstacle within this area is related to a profile which has an upward slope 1.0 per cent from the origin out to 9 000 m from the origin, where the plane continues horizontally at 90 m. Where this survey plane touches no obstacle, it is to be reduced until it touches the first frangible obstacle or reaches 0.5 per cent.

4.2.4 In the first 900 m, obstacles are considered to cast a horizontal shadow forwards: from 900 m to 9 000 m, the shadow has an upward slope of 1 per cent; from 9 000 m outwards, the shadow is again horizontal. Obstacles lying wholly beneath such shadows need not be shown on the chart (but see 4.2.5 For selective shadowing procedure). In addition, in the outer sector from 9 000 m to 15 000 m, obstacles may be considered to cast a backward shadow of slope of 10 per cent. All obstacles lying wholly beneath such shadows need not be shown (but see 4.2.5 for selective shadowing procedure).

4.2.5 Current UK legislation allows the pilots of smaller aircraft to consider an obstacle-accountable take-off flight path area (TOFPA) of lesser total width than that defined in 4.2.3. In order to ensure that obstacles in this area are not eliminated from the Type A chart by use of an obstacle shadowing technique universally applicable over the whole area, a selective obstacle shadowing procedure is adopted. For obstacle shadowing purposes, the take off flight path area (TOFPA) described in 4.2.3 is initially surveyed for all accountable obstacles. It is then divided into three sections. Each of the two outermost sections consists of a strip 25 m wide, running parallel to its respective outer edge of the TOFPA. The accountable obstacles in the central section are permitted to shadow obstacles in the two outermost sections. Accountable obstacles in the two outermost sections are not permitted to shadow obstacles in the central section. Accountable obstacles in either of the outermost sections are not permitted to shadow obstacles in the other outermost section.

4.2.6 The order of accuracy required is that given in Annex 4, Chapter 3, 3.9.

4.2.7 If a turned take-off climb area is considered necessary, the area to be surveyed shall be determined by consultation between the appropriate aerodrome authority and the operators.

4.1.8 Other runways. These will conform to the specifications of Annex 4.

AGA survey

4.2.9 All obstacles are to be determined which penetrate:

- a) the runway strips;
- b) the taxiway strips;
- c) the approach surface;
- d) the take-off surfaces,
- e) the transitional surfaces;
- f) the horizontal surfaces;
- g) the conical surfaces.

4.2.10 The dimensions and slopes of obstacle-accountable surfaces are to be determined by a combined study of MAS 1 and CAP 168. Where differences occur, the more demanding specification is to be selected.

4.2.11 Accuracy of survey is to be in accordance with Annex 4, Chapter 4, 4.9.

RAC survey (for precision approach procedures)

4.2.12 A detailed survey is required for all categories of ILS procedures and surveillance radar approaches (SRA) to a termination range of 1/2 NM. The most demanding of the requirements for these procedures, the ILS category I profile and the plan area of the SRA procedure, are used as the basis of the survey. All obstructions in the plan area which penetrate or come within 3 m of the obstacle clearance surfaces must be included in a schedule of measured heights. A computer is used to accept the data in the form described in 4.2.21 and 4.2.22, and is programmed to calculate the obstacle clearance limit (OCL) and dominant obstacle allowance (used only in the United Kingdom) for all categories of ILS. For safeguarding purposes, sample checking of the computer ILS output and manual calculation of 1/2 NM SRA OCLs, a survey plan to scale of 1:5000 will also be required. Alternative scales of 1:2500 or 1:10000 may be acceptable for certain

aerodromes. Surveys are required to be updated annually and completely renewed every three years.

4.2.13 The approach funnel has its origin at the landing threshold where it is 600 m wide: 660 m downwind of the threshold, it diverges at the rate of 15 per cent (equivalent to an angle of $8^{\circ} 32'$) on each side until it reaches a width of 4 NM, and then remains at this width out to 15 NM from the threshold. The profile of the approach funnel is horizontal for the first 790 m, and beyond this it has an upward slope of 1:32. The missed approach begins at the threshold, where it is 600 m wide, and remains constant in width until 875 m upwind of the threshold, where it diverges at an angle of 150 on each side. The profile of the missed approach is horizontal for the first 1800m upwind of the threshold, and then has an upward slope of 1:40. The area terminates when the slope intersects the minimum sector altitude.

4.2.14 The survey requirements detailed in 4.2.12 and 4.2.13 were devised to meet the obstacle assessment requirements for all existing UK precision approach procedures, for which the height above aerodrome elevation below which the minimum prescribed vertical clearance cannot be maintained is defined as the obstacle clearance limit (OCL), i.e. in accordance with the criteria in PANS-OPS, Third Edition, 1971. The survey requirements for all new precision approach procedures and all existing procedures are being amended to ensure that the obstacle assessment surfaces (OAS) compile with the requirements of PANS-OPS, Volume II, First Edition, 1979, and all subsequent amendment to that document as approved by the Air Navigation Commission, From 25 November 1982, the applicability date of the new PANS-OPS. The minimum permissible aircraft height criteria for each precision approach procedure have been referred to as "obstacle clearance altitude/height (OCA/H)".

Airport survey procedures

4.2.15 Within the United Kingdom the fullest use is made of national plans. The whole of the United Kingdom, including Northern Ireland, is mapped on the transverse Mercator projection. A national grid system is superimposed on the maps of England, Scotland and Wales; Northern Ireland is included in the Irish grid system, the central meridian of the projection being 80W of Greenwich as opposed to the 2° W value used for the remainder of the United Kingdom.

4.2.16 Complete map coverage at a scale of 1: 10 000 or 1:10 560 is available. The majority of airports being surveyed are in areas where national plans at a scale of 1:2500 are published. These plans give bench mark position and elevation above

datum, with spot levels along public highways. It is against this background that the United Kingdom surveys are carried out.

4.2.17 Airport obstacle surveys are designed to cover the requirements stated in ICAO Annexes 4 and 14 and the criteria in CAP 168 where these are applicable to obstacle surveys.

Field work

4.2.18 Field work is usually carried out on copies of the 1:2500 national plans where they exist. In remote areas not mapped at 1:2 500 scale, the 1:10 000 or 1:10 560 plans are used. The survey is aimed at the production of plans and schedules of measured heights. This requires:

- a) a check on the alignment and length of runways, threshold elevations, and the general layout of the aerodrome as appearing on the plan being used;
- b) marking of the zones and permissible heights for take- off, landing and circling operations on the field copies of the plans;
- c) location on the plan of the points to be heighted;
- d) heighting. Height differences are obtained by multiplying the tangent of the vertical angle, measured by theodolite observation, by the scaled distance between the plan- positions of the instrument and the object being heighted. This difference is applied to the elevation of the instrument station to obtain the height above datum for the particular object. At least two determinations of height, each from a different instrument station, must be obtained for each point heighted.

Office work

4.2.19 Alternatively, surveys may be carried out by aerial photography and the results verified by field survey sampling.

4.2.20 The points heighted are ploued on a dimen- sionally stable plastic transparency of the appropriate 1:2 500 national grid plan and are identified by a unique number. As many as possible of these pain ts are also plot- ted on a 1:10000 compilation of the 1:10 000 or 1:10 560 national grid plans covering the airport and various approach, take-off and circling areas. Each plan is. given a reference number and the survey authority responsible for the information is stated.

4.2.21 A schedule of measured heights, in book form, is prepared. The title page states:

- a) name of airport;
- b) area covered by survey;
- c) the national grid co--ordinate of each runway threshold correct to ± 1 m;
- d) the elevation above ordnance datum of each runway threshold to ± 0.03 m;
- e) date of survey and any revision;
- f) a record number;
- g) the name of the survey authority responsible for the information.

4.2.22 Each page of the schedule contains the following information:

- a) the record number of the plan on which the heightened point is plotted;
- b) the plan number of the point:
- c) height of point above datum ± 0.3 m;
- d) the 1 m national grid reference of each point, normally obtained by scaling from the 1:2 500 national grid plan;
- e) brief description (limited to eight digits for computer input requirements).

4.2.23 Transparent positive copies of these plans are produced on dimensionally stable plastic material and issued to the appropriate authority together with copies of the schedule. From the information they contain, aviation officials can then decide which objects constitute an obstacle,

4.2.24 The field survey and subsequent office procedures ensure that the data supplied is more than adequate for the production of Type A and Type B charts, and allow for a more detailed study of approaches.

4.2.25 The surveys are, in general, carried out from highways and by-ways, and arrangements for land entry are not normally necessary. In all cases, the surveyor is informed as to the type of survey required in the following terms:

- a) Comprehensive survey: this is a first survey or a resurvey showing all obstacles and contours. Land entry is essential;

b) Limited survey: this is first survey or a resurvey showing only representative obstacles in groups of closely clustered objects. It is carried out from highways and by-ways, and land entry is not normally necessary;

c) Revision survey: this is a check survey carried out where airports have previously been accurately surveyed and where only limited new construction and obstacle clearance programmes have taken place.

4.2.26 For each airport an indication is given as to whether the runways and strips are instrument or visual, and the exact dimensions and slopes of the approach areas related to these are also defined. The requirements for AGA surveys include the transitional, horizontal and conical surfaces as given in MAS 1 and CAP 168.

4.2.27 If examination of the Plan and Schedule of Measured Heights shows the need for a clearance programme, a resurvey is carried out of the particular area involved, usually requiring land entry to be arranged, and a 1 :2 500 scale plan is prepared to show in detail those objects to be removed and to allow costs to be estimated.

4.3 UNITED STATES OF AMERICA PRACTICE

4.3.1 The airport obstacle survey must supply, principally:

a) the airport elevation;

b) runway profile elevations;

c) the latitude and longitude of the airport reference point (ARP);

d) the width and length of each runway;

e) the azimuth of each runway;

f) the planimetry at the airport and

g) the location and elevation of each obstacle in the area covered by the chart.

Where additional information may be required by some States, the procedures described below for obtaining the principal data can be applied to provide the additional data.

4.3.2 The complexity of each survey and the number of charts maintained will vary greatly from State to State. The survey methods, equipment and support required for the field survey personnel will also vary. The range of field procedures described

herein is sufficiently wide to provide a choice of methods suitable for the very complex as well as for the simpler survey situation. In this respect, many of the methods assume the use of aerial photographs during the survey, followed by office photogrammetric compilation processes. Where photo-grammetric procedures are not considered practicable, field methods may be selected which do not depend on such procedures. Compilation and reproduction facilities among the States, also, vary so much that no comments on these Phases are included.

4.3.3 For ease of reference, the field survey is considered in a series of steps or processes:

- a) original surveys;
- b) revision surveys;
- c) planning and reconnaissance;
- d) levelling;
- e) horizontal control;
- f) landing area survey;
- g) obstacle detection and selection;
- h) obstacle locations and elevations;
- i) air navigational aids (ILS, RBN, Radar, etc).

Original surveys

4.3.4 An original survey is defined as the first obstacle survey made at an airport. This survey must provide all the principal data, including any supplemental data required. Moreover, the original survey should provide a basic net of horizontal and vertical control stations - described and monumented to ensure their recovery and use on future revision surveys. Provided the extra expense is warranted, the control should be of an order of accuracy useful to airport officials and local engineers for their surveying requirements.

Revision surveys

4.3.5 During each revision survey, the field party must make a thorough field examination the existing obstacle chart, and supply all the field survey data required

to update the chart whereby it conforms with the current requirements. The kind and volume of field work required for a revision survey will vary considerably, depending upon the age of the chart. A field examination of the charted obstacles is mandatory. For this purpose, the existing chart maybe used as a plane-table sheet if it is a new or relatively new obstade chart, this may be practically all that is required of a revision survey. On an older obstacle chart, additional work will often be necessary, such as re-establishing the airport reference point (ARP), new runway levelling, revision of the horizontal and vertical control scheme, and so on.

Planning and reconnaissance

4.3.6 Planning of the individual survey should start with a study of the best available maps of the area and of the existing horizontal and vertical control in the area. It is always helpful to plot the approach surfaces, etc., on the maps during this study. The study should be followed by preliminary conferences with the airport manager, control tower personnel, and airport engineer regarding the survey, proposed construction or dearing, critical obstacles, and existing control. Following the preliminary conferences, a general reconnaissance should be made to gain familiarity with the airport and vicinity.

Levelling

4.3.7 To establish the required airport elevation, including runway profile elevations and bench marks from which obstacle elevations will be determined, spirit levelling of third-order or higher accuracy should be run to the airport. This levelling should be run forward and backward from two existing bench marks between which a satisfactory check is obtained and which are based on mean sea level elevations. Where it is not practicable to base this levelling on a mean sea level datum, a note to that effect should appear on the chart. During this levelling, at least two monumented and described bench marks should be established ai the airport for future use.

4.3.8 From these new bench marks, a closed loop of spirit levels should be run around the perimeter of the landing area, and a semi-permanent point, marked and described, should be established near the end of each runway for future use. A loop closure of $0.1 \text{ ft}^{(1)}$ times the square root of the length of the level line in statute miles is satisfactory for this levelling. The runway profile levelling and the elevation of the airport can be determined by levelling from the. e bench marks. Levelling, also, can be extended from these bench marks outward from the airport to the vicinity of obstacles where previously established bench marks do not exist.

⁽¹⁾ *The material in this section uses English units of measurement in conformity with the United States practice.*

4.3.9 All of the above levelling can be carried out with any good quality spirit level and an accurate level rod. During the levelling the instrument should be kept in good adjustment, and the length of the foresights and backsights should be kept in balance.

Horizontal control

4.3.10 A correct relationship must be shown on the chart between the airport runways, the obstacles and other details. It is the purpose of the horizontal control survey to determine this relationship. This is usually accomplished by taping a base line along one of the runways and extending from this base by a small net of triangulation or traverse until the positions, with respect to the base line, have been determined for as many local control stations as are required.

4.3.11 The number of local control stations that are required will depend on whether or not photographs are to be used during the obstacle location and elevation survey. Where this will be done by the use of aerial photographs and photogrammetric processes about three stations at the ends of the runways, a station at the airport reference point and an outlying station just beyond the limits of the obstacles in each direction from the airport will suffice. Where aerial photographs will not be used, one local control station will be required at the airport reference point and one at the end of each runway. Enough additional outlying stations also will be required to permit the location, from these stations, of each obstacle, or other detail, by plane-table, or theodolite intersection, or traverse.

4.3.12 Plane co-ordinates for each local control station can be computed by assuming starting co-ordinates at one end of the base line and an azimuth for the base line. An improvement would be to observe a sun azimuth for the base line, as this would orient the co-ordinate system for the chart to true north. An additional improvement would be to connect the scheme of local control stations to a national system of horizontal control by photogrammetric methods, triangulation, or traverse. This will place the co-ordinate system of the chart on a geodetic datum and make it possible to determine the geographic position of the airport reference point, since this is one of the local control stations, or of any other point on the chart. Where it is not practicable to determine the geographic position of the airport reference point in this manner, it will be necessary to scale its position from the best map available.

4.3.13 Sufficient accuracy will be obtained if the base line is taped in both forward and backward directions with a good quality steel tape, supported throughout by the runway surface, and if the tape is corrected for temperature only. Again, the accuracy will be sufficient if the angles are observed with a transit or theodolite having at least a 20" division of the horizontal circle, and if two direct and reverse measurements of each angle are made.

Landing area survey

4.3.14 The purposes of the landing area survey are to establish the width, length and azimuth of each runway, and to provide the survey notes required for the compilation of the planimetric detail at the airport.

4.3.15 The runway widths are determined readily by taping; the lengths, also, can be obtained by this method. The lengths, alternatively, can be determined by inverse computation between local control stations established at each end of each runway during the horizontal control work. Where this method is used, the computation will also provide the runway azimuths. A third method, where photogrammetric methods are used to connect the local control stations to a national horizontal control system, is to identify each runway end on a photograph, determine co-ordinates for these points by photogrammetric methods, and then compute length and azimuth from these co-ordinates. Finally, where lengths are determined by taping, a sun azimuth observation can be observed to determine the azimuth of one runway, and an angular traverse run to each of the other runways for the determination of their azimuths.

4.3.16 Photogrammetric detailing is ideal for the compilation of planimetric detail at the airport, that is, the detailing on the chart of runways, taxiways, buildings, etc. Where this process is used, the field work may be limited to notes on the photograph indicating to the office compiler any changes that have occurred since the date of the photography. The required detail is best determined by plane-table methods where photogrammetric detailing will not be used.

Obstacle detection and selection

4.3.17 The locations and the elevations of obstacles comprise the most important information shown on an obstacle chart. The party personnel must be thoroughly familiar with the imaginary surfaces that define obstacles. The validity of the published obstacle chart depends upon the care and judgement exercised by field party personnel in the detection and selection of obstacles, and in the subsequent work of locating them and determining their elevations.

4.3.18 Obstacles within an approach area that are visible from the runway end may be detected by sweeping the area from near the runway end with a theodolite telescope. For this purpose, the telescope is set at the vertical angle equivalent to the slope of the approach surface (1009' for a fifty- to-one slope, or 1026' for a forty- to-one slope, or 0°41' for a 1.2 per cent slope) Allowance must be made for any displacement of the telescope above or below the plane of the approach surface. When this method is used, care must be taken to check by other methods for the existence of obstacles that may be obscured from view at the runway end.

4.3.19 The field detection of obstacles for the remainder of the area will be greatly expedited by careful study of the existing topographic maps. This map reconnaissance must be visually checked by ground reconnaissance on foot, by truck or by light aircraft. The type(s) of inspection made will depend on the extent of the area, the availability of roads, and the nature of the terrain.

4.3.20 Frequently, an approximate test elevation will be needed to determine whether an object is to be classified as an obstacle for final location and determination of the elevation. Where the test elevation indicates that an object is an obstacle, other objects in the vicinity may be compared with it by eye or stereoscopic study of photographs to decide whether or not they also may be obstacles. Test elevations for detection of obstacles may be determined by vertical angles observed from a point of known elevation (elevation from a topographic map or other source) with a distance scaled from a map or photograph. Observation points for these approximate test elevations may be roofs of buildings, high ground, runway ends, and so on, Alertness is required to include mobile objects such as trains, truck . travelling cranes, and, in some cases, even boats, where they cross the flight path close to the runway ends.

4.3.21 The selection of obstacles to be charted is the next step. It is often not practicable to chart every obstacle that is detected in the field. A selection must be made to include the most important obstacles, plus those portraying obstacle nature and distribution throughout the chart area. An effort should be made to portray the density of obstacles in each area by selecting a few more obstacles in areas where the density is greater than are selected in less congested areas.

Obstacle locations and elevation

4.3.22 The location (horizontal position) must be determined for each obstacle selected for charting. The location may be determined by field identification on aerial photograph for subsequent positioning by office photogrammetric methods, or by ground survey methods - by triangulation, traverse, or a combination thereof.

4.3.23 The photogrammetric method is very satisfactory. It limits the field location work to the identification on the photographs of the image of each obstacle and of a sufficient number of horizontal control stations to control the photogrammetric bridge or plot. Where this method is not available, obstacle locations may be determined by triangulation intersection methods, by traverse, or by plane-table, or by a combination of these.

4.3.24 Obstacle elevations can be very satisfactorily determined by stadia-trigonometric levelling, or by horizontal and vertical angles observed to the top of the obstacle from a minimum of two points of known elevation and horizontal position.

Chapter 5
AIRPORT EQUIPMENT AND INSTALLATIONS
WHICH MAY CONSTITUTE OBSTACLES

5.1 INTRODUCTION

5.1.1 All fixed and mobile objects, or parts thereof, that are located on an area intended for the surface movement of aircraft or that extend above a defined surface intended to protect aircraft in flight, are obstacles. Certain airport equipment and installations, because of their air navigation functions, must inevitably be so located and/or constructed that they are obstacles. Equipment or installations other than these should not be permitted to be obstacles. This Chapter discusses the siting and construction of airport equipment and installations which of necessity must be located on: a runway strip; a runway end safety area; a taxiway strip, or within the taxiway clearance distance specified in MAS 1, Table 3-1, columns 5 and 6; or on a clearway, if it would endanger an aeroplane in the air.

5.1.2 When airport equipment, such as a vehicle or plant, is an obstacle, it is generally a temporary obstacle. However, when airport installations, such as visual aids, radio aids and meteorological installations, are obstacles, they are generally permanent obstacles.

5.1.3 Any equipment or installation which is situated on an airport and which is an obstacle should be of minimum practicable mass and height and be sited in such a manner as to reduce the hazard to aircraft to a minimum. Additionally, any such equipment or installation which is fixed at its base should incorporate frangible mountings (see 5.2).

5.1.4 The degree to which equipment and installations can be made to conform to the desired construction characteristics is often dependent on the performance requirements of the equipment or installation concerned. For example, frangibility and low-mass construction characteristics may have an adverse effect on the rigidity of a transmissometer support.

5.1.5 Many factors must be considered in the selection of aid fixtures and their mounting devices to ensure that the reliability of the aids is maintained and that the hazard to aircraft in flight or manoeuvring on the ground is minimal. It is therefore important that appropriate structural characteristics of all aids which may be obstacles be specified and published as guidance material for designers. To this end,

some guidance on the frangibility requirements of airport equipment and installations is included in 5.3.

5.2 FRANGIBILITY

5.2.1 The frangibility of an object is its ability to retain its structural integrity and stiffness up to a desired maximum load, but on impact from a greater load, to break, distort or yield in such a manner as to present the minimum hazard to aircraft.

5.2.2 An object which meets the above requirements is said to be frangible.

5.3 TYPES OF AIRPORT EQUIPMENT

AND INSTALLATIONS WHICH MAY CONSTITUTE OBSTACLES

5.3.1 General

5.3.1.1 There are many types of airport equipment and installations which, because of their particular air navigation functions, must be so located that they constitute obstacles. Such airport equipment and installations include:

- a) ILS glide path antennas;
- b) ILS inner marker beacons;
- c) ILS localizer antennas;
- d) wind direction indicators;
- e) landing direction indicators;
- f) anemometers;
- g) ceilometers;
- h) transmissometers;
- i) elevated runway edge, threshold, end and stopway lights;
- j) elevated taxiway edge lights;
- k) approach lights;
- l) visual approach slope indicator system (VASIS) lights;

- m) signs and markers;
- n) components of the microwave landing system (MLS);
- o) certain radar and other electronic installations and other devices not itemized above;
- p) VOR or VOR/DME when located on aerodromes;
- q) precision approach radar systems or elements;
- r) VHF direction finders; and
- s) airport maintenance equipment, e.g. trucks, tractors.

5.3.1.2 There is wide variation in the structural characteristics of these aids currently in use. Nevertheless, it is necessary that States develop material on appropriate structural characteristics of these aids for the guidance of designers. Details of the structural nature of ILS antennas and transmitters employed by certain States are given below (5.3.2 through 5.3.4), together with guidance material developed by the Visual Aids Panel on the structural requirements of runway, taxiway and approach lights, and other aids (5.3.5 through 5.3.7).

5.3.2 *ILS glide path antennas*

5.3.2.1 *Federal Republic of Germany.* ILS glide path antenna masts used in the Federal Republic of Germany consist of thin-walled large-diameter tubes which are slightly cone-shaped and made from fibreglass material with short glass fibres (see Figure 5-1). These masts can resist considerable wind loadings but they will break with the application of a load such as would be imposed in the event of impact by an aircraft (see Figure 5-2).

5.3.2.2 *France.* In France, the masts of ILS glide path antennas are made of steel angle members. Their cross-section is an equilateral triangle with 1 m sides, and they have welded braces at 0.7 m vertical intervals. Depending on the type of glide path, the mast height varies between 15 and 17.5 m. A compromise between strength (wind resistance) and fragility is made by a weakening in the upper section of the tower, 10 m from the ground, obtained by saw cuts in the gusset plates connecting sections of the structure. The calculated direct failure load is 492 kgf applied at the top of the mast.

5.3.3 *ILS localizer antennas*

5.3.3.1 *United Kingdom.* One of the localizer antennas in use within the United Kingdom is the horn type. The horn antenna system is constructed of low-mass, low-impact strength materials. The major support brackets are mechanically fused to shear on impact, and the truncated corner reflector consists of closely spaced stainless steel wires stretched horizontally between the end spars of the main frame. The main frame is mounted on support brackets which are secured to a concrete base to produce an array of approximately 5.5 m height. The antennas are 25 to 50 m in length. In the event of an aircraft overrunning the runway and colliding with the antenna, the fuse pins in the front support brackets shear, and the entire frame folds back to the ground causing minimal damage to the aircraft. Similarly, on collision from the rear, say on a low approach, the array will fold forward.

5.3.3.2 *Federal Republic of Germany.* ILS localizer antenna support used in the Federal Republic of Germany consist of thin-walled tubes made from fibreglass material with short glass fibres. The maximum height of the installation is about 3 m (see Figure 5.3). The reflectors of the localizer antennas are rods approximately 2,5 m long, which are held by springs only.

When exposed to loads in excess of the design load, they jump out of their supports and thus minimize the hazard to an aircraft overrunning the runway.

5.3.3.3 *Australia.* One type of localizer antenna employed in Australia comprises aluminium-clad balsa wood spars supported by aluminium tubing. The supporting structure incorporate shear pins at critical points to allow the structure to collapse under impact.

5.3.3.4 *France.* Localizer antennas used in France are parabolic reflectors with a span of 35 m, made up of 19 vertical steel tubes connected by copper wire. These steel tubes have a diameter of 70mm, and are 3.75 mm thick. They are braced by a strut at an angle of 45° secured at the mid-point of the antenna height. The reflecting surface consists of 56 horizontal copper wires of 2,5mm diameter. The reflector is designed to withstand dynamic pressure resulting from a non-icing wind at 125 km/h, and to resist elastic deformation likely to interfere with at wind speeds suitable for landing operations. The calculate direct loads at fracture are: 108 kgf applied in the normal landing direction; and 44 kgf in the opposite direction. (These loads vary according to the angle of application associated with curvature of the reflector and tension exerted by the wires.)

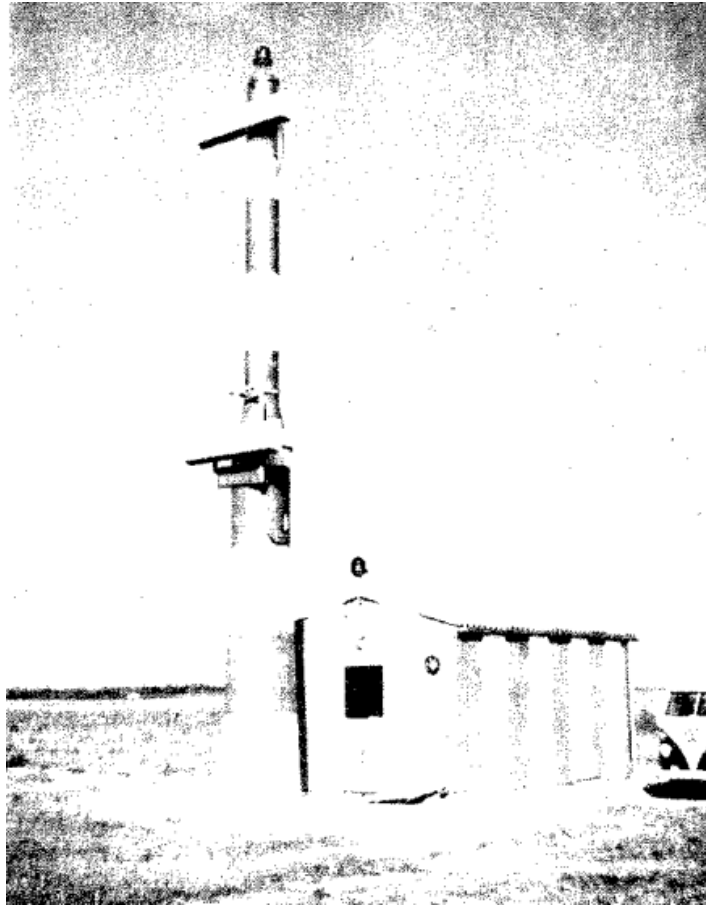

Figure 5-1. ILS glide path antenna mast used in the Federal Republic of Germany

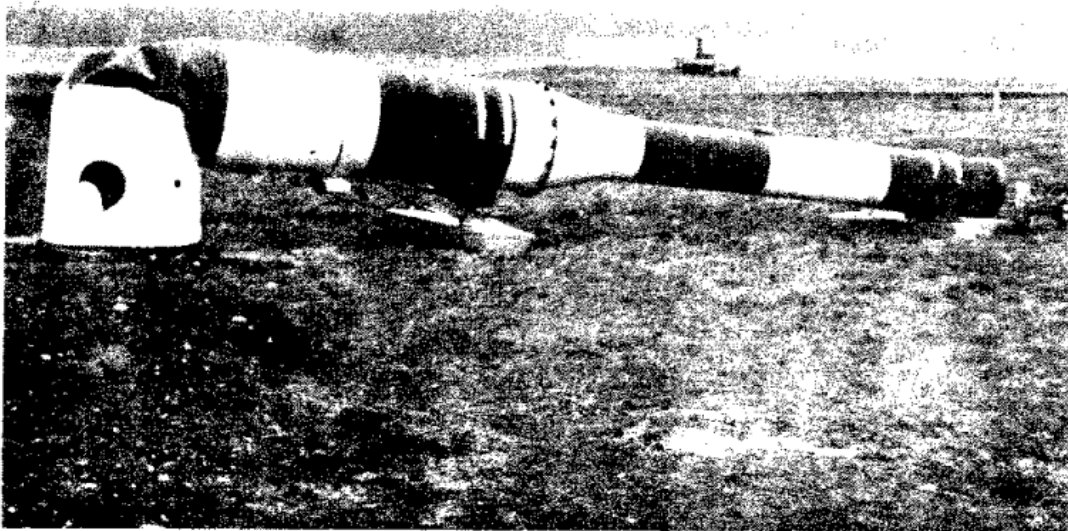

Figure 5-2. Fractured ILS glide path antenna mast used in the Federal Republic of Germany.

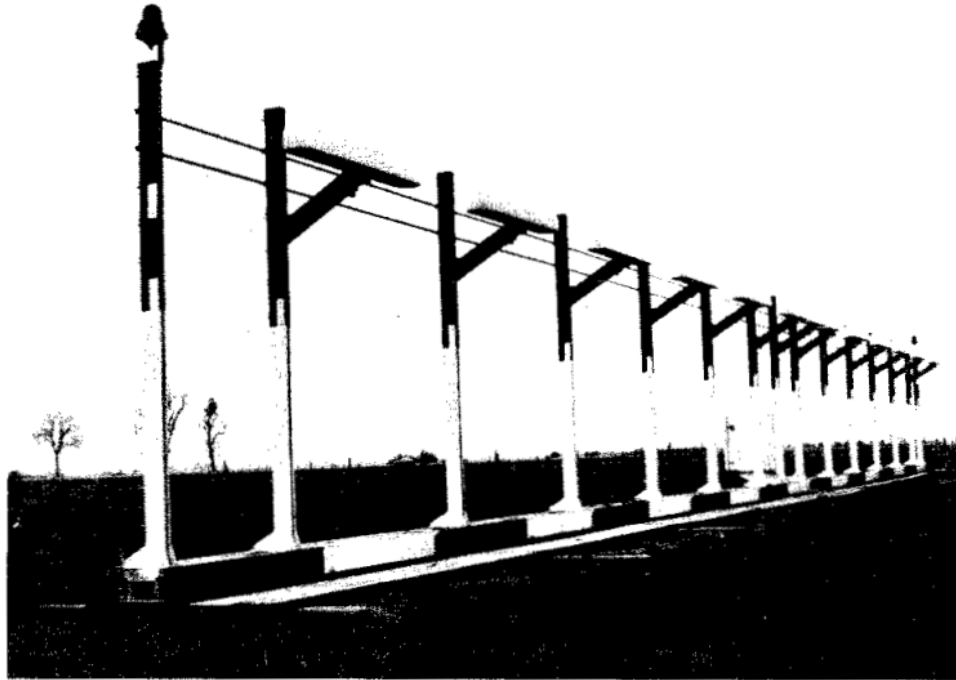

Figure 5-3. ILS localizer antenna array used in the Federal Republic of Germany.

5.3.4 Transmissometers

5.3.4.1 United Kingdom. In the United Kingdom, transmissometers and reflectors are each contained in a brittle glass fibre housing having the following physical characteristics:

Height - 1.83 m

Diameter - 0.74 m

Maximum mass - 89 kg

Greatest mass concentration - 34 kg at a height of approximately 1.5 m

The units are held in position by a single-necked bolt to produce a structure that will break off under a lateral load of 227 kgf.

5.3.4.2 Federal Republic of Germany. On airports within the Federal Republic of Germany, trans- missometers are mounted on a base constructed of asbestos cement, glass-reinforced polyester or aluminium cast pipes. The manufacturers claim that these trans-missometers mountings will rupture at a bending moment of 400 N.m.

5.3.4.3 *Kingdom of the Netherlands.* In the Kingdom of the Netherlands, the structure on which the transmissometers is placed is constructed of hollow aluminium tubes that, although sufficiently strong by themselves, bend or break easily should an aircraft collide with them. The structure is attached to a sunken concrete foundation by means of breakable bolts.

Note. - *The guidance material on the structural requirements of certain visual aids in 5.3.5 through 5.3.7 was developed by the Visual Aids Panel.*

5.3.5 *Elevated runway edge, threshold, end, stopway and taxiway edge lighting*

5.3.5.1 The height of these lights should be sufficiently low to ensure propeller and engine pod clearance. Wing flex and strut compression under dynamic loads can bring the engine pods of some aircraft to near ground level. Only a small height can be tolerated, and a maximum height of 36 cm is advocated.

5.3.5.2 These aids should be mounted on frangible mounting devices. The impact load required to cause failure at the break point should not exceed 5 kg-m and a static load required to cause failure should not exceed 230 kg applied horizontally 30 cm above the break point of the mounting device. The desirable maximum height of light units and frangible coupling is 36 cm above ground. Units exceeding this height limitation may require higher breaking characteristics for the frangible mounting device, but the frangibility should be such that, should a unit be hit by an aircraft, the impact would result in minimum damage to the aircraft.

5.3.5.3 In addition, all elevated lights installed on runways of code letters A and B should be capable of withstanding a jet engine exhaust velocity of 300 kt, and lights on runways of code letters C, D and E, a lower velocity of 200 kt. Elevated taxiway edge lights should be able to withstand an exhaust velocity of 200 kt.

5.3.6 Approach lighting system

5.3.6.1 Guidance on the frangibility of approach lights is more difficult to develop, as there is a greater variation in their installation. Conditions surrounding installations close to the threshold are different from those near the beginning of the system: for example, lights within 90 m of the threshold or runway end are required to withstand a 200 kt blast effect, whereas lights further out need only withstand a 100 kt blast or the natural environmental wind load. Also the terrain close to the threshold can be expected to be near the same elevation as the threshold, thus permitting the lights to be mounted on short structures. Farther from the threshold, support structures of considerable height may be required.

5.3.6.2 To minimize the hazard to aircraft that may strike them, approach lights should have a frangible device, or their supports be of a frangible design.

5.3.6.3 Where the terrain requires light fittings and their supporting structure to be taller than approximately 1.8 m and they constitute the critical hazard, it is considered that it is not practicable to require that the frangible mounting device be at the base of the structure. The frangible portion may be limited to the top 1.8 m of the structure, except if the structure itself is frangible. Though there is some question of the need to provide frangibility for approach lights installed beyond 300 m before the threshold (as these lights are required to be below the approach surface), it is recognized that protection needs to be provided for aircraft that might descend below the approach or take-off surfaces. A frangible top portion of 1.8 m is considered to be a minimum specification, and a longer frangible top portion should be provided where possible.

5.3.6.4 In all cases, the unit and supports of the approach lighting system should fail when an impact load of not more than 5 kg.m and a static load of not less than 230 kg is applied horizontally at 30 cm above the break point of the structure.

5.3.6.5 Where it is necessary for approach lights to be installed in stopways, the lights should be inset in the surface when the stopway is paved. When the stopway is not paved, they should either be inset or, if elevated, meet the criteria for frangibility agreed for lights installed beyond the runway end.

5.3.7 Other aids (for example, VASIS, signs and markers)

5.3.7.1 These aids should be located as far as practicable from the edges of runways, taxiways and aprons as is compatible with their function. Every effort should be made to ensure that the aids will retain their structural integrity when subjected to the most severe environmental conditions. However, when subjected to aircraft impact in excess of the foregoing conditions, the aids will break or distort in a manner which will cause minimum or no damage to the aircraft.

5.3.7.2 Caution should be taken, when installing visual aids in the movement area, to ensure that the light support base does not protrude above ground, but rather terminates below ground as required by environmental conditions so as to cause minimum or no damage to the aircraft overrunning them. However, the frangible coupling should always be above ground level.

Appendix 1
Illustrations of Obstacle Limitation Surfaces Other Than Those Constituting an Obstacle-Free Zone

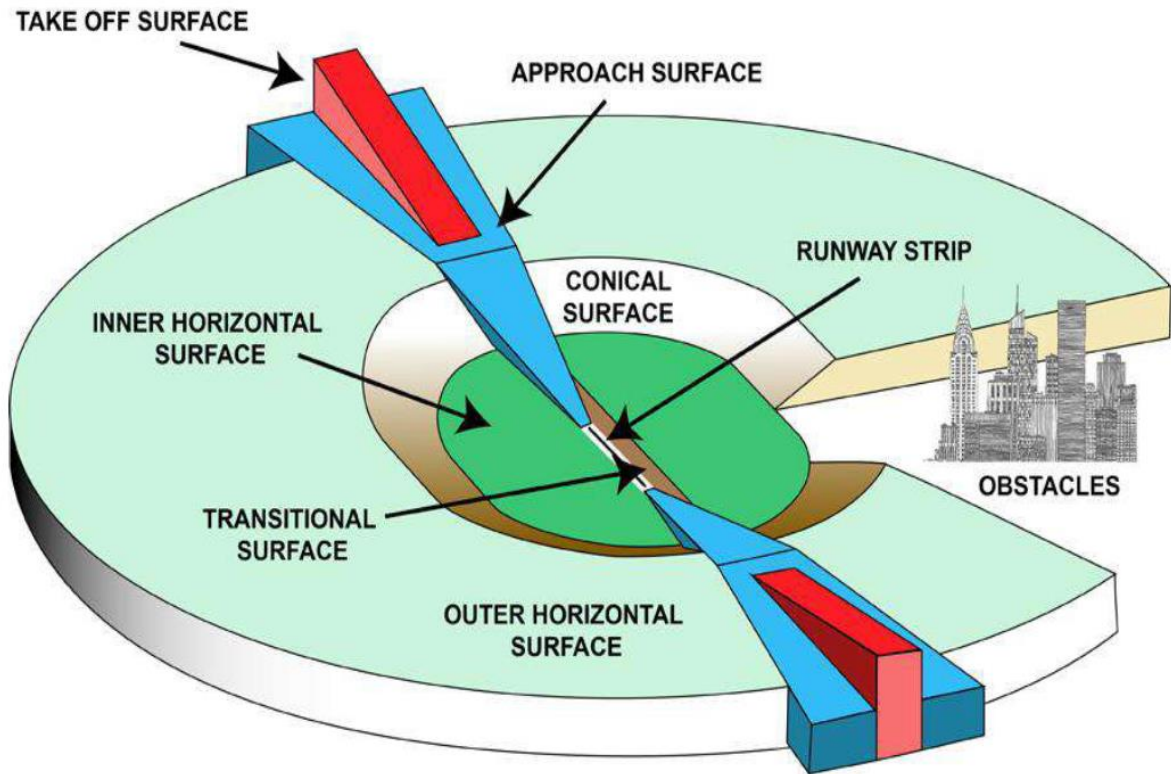

Figure 2: Plan view of an approach surface

OBSTACLE LIMITATION SURFACES

Note. — The figure shows the obstacle limitation surfaces at an aerodrome with two runways, an instrument runway and a non-instrument runway. Both are also take-off runways.

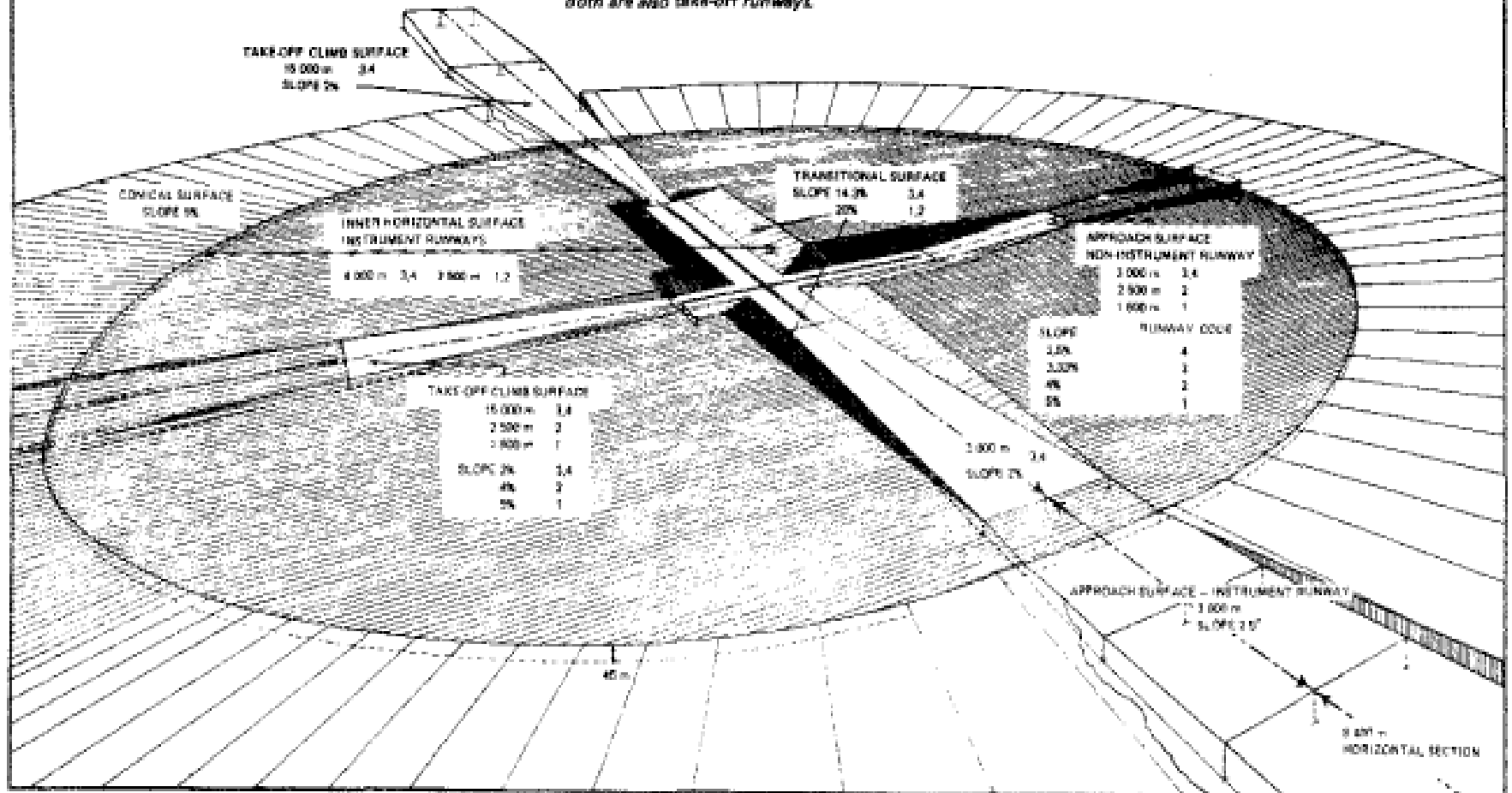

Figure A-1-1
74

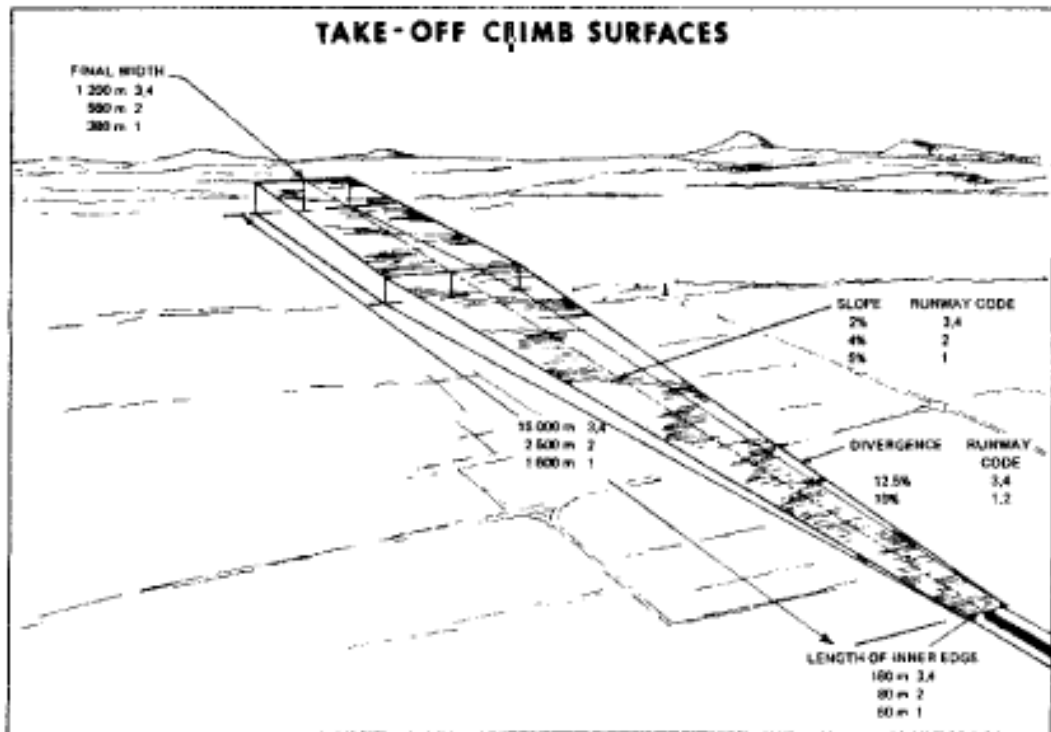

Figure A-1-2

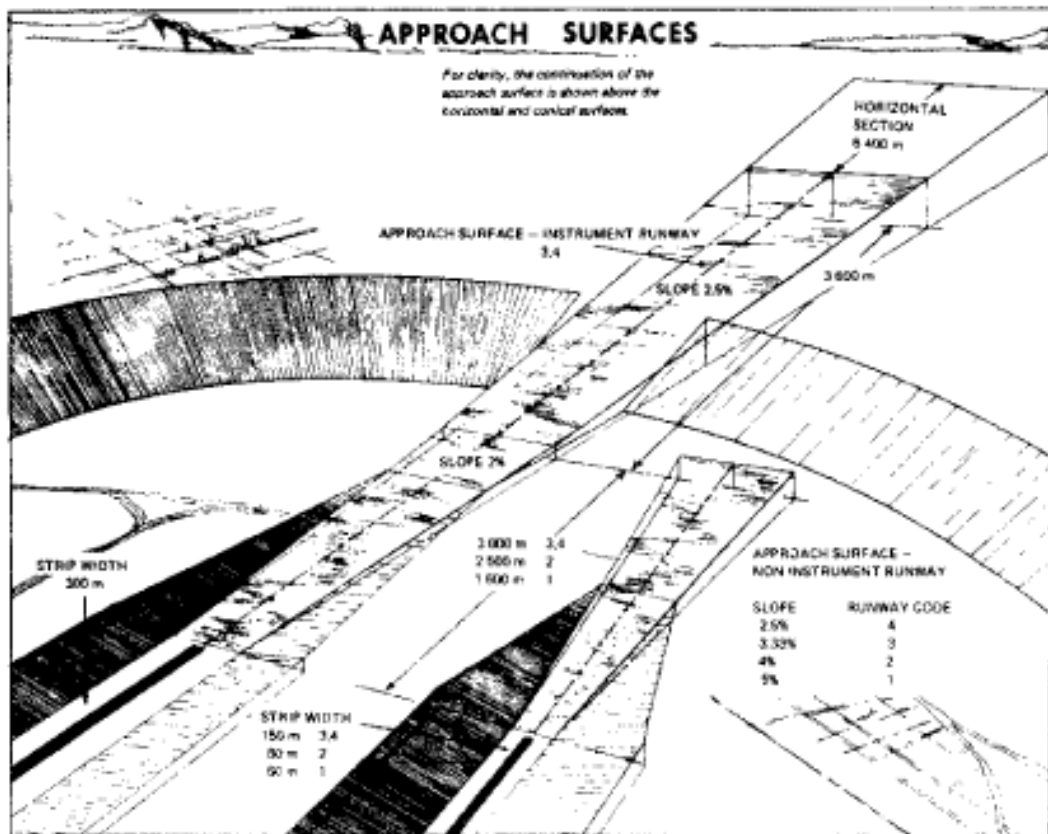

Figure A-1-3

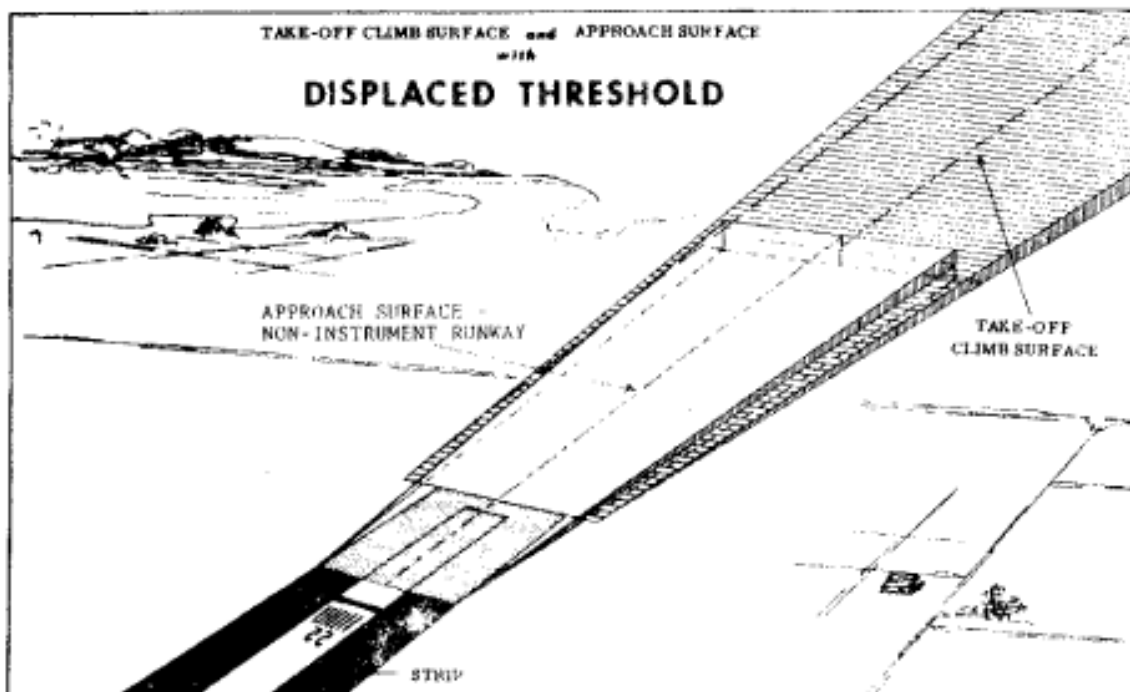

Figure A-14

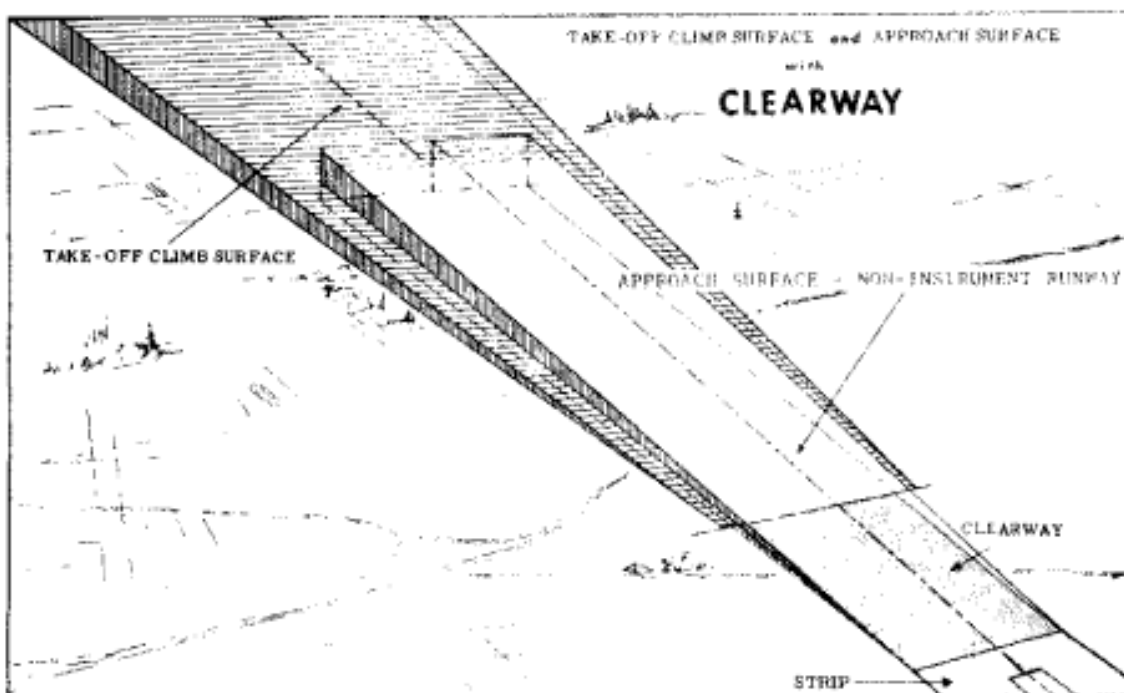

Figure A-15

Appendix 2

Model Zoning Ordinance to Limit Height of Objects Around an Airport

Nore. - The following model zoning ordinance to limit the height of objects around an airport was extracted from the US FAA Advisory Circular No. 150/5190-4. It has been reproduced here to illustrate broadly the essential elements of a zoning ordinance. It is not intended that all zoning laws should follow the same format or include similar provisions. It is important to note that in several instances the ordinance uses terms and dimensions different from those used/specified in MAS 1. Furthermore, it does not employ the new Aerodrome Reference Code which has been used in the remainder of the manual.

AN ORDINANCE REGULATING AND RESTRICTING THE HEIGHT OF STRUCTURES AND OBJECTS OF NATURAL GROWTH, AND OTHERWISE REGULATING THE USE OF PROPERTY IN THE VICINITY OF THE -----²/ BY CREATING THE APPROPRIATE ZONES AND ESTABLISHING THEREOF; PROVIDING FOR CHANGE IN THE RESTRICTIONS AND BOUNDARIES OF SUCH ZONES; DEFINING CERTAIN TERMS USED HEREIN; REFERRING TO THE -----²/ ZONING MAP WHICH IS INCORPORATED IN AND MADE A PART OF THIS ORDINANCE; PROVIDING FOR ENFORCEMENT; ESTABLISHING A BOARD OF ADJUSTMENT; AND IMPOSING PENALTIES

This Ordinance is adopted pursuant to the authority conferred by -----³. It is hereby found that an obstruction has the potential for endangering the lives and property of users of-----², and property or occupant of land in its vicinity; that an obstruction may affect existing and future instrument approach minimums of-----²; and that an obstruction may reduce the size of areas available for the landing, takeoff, and maneuvering of aircraft, thus tending to destroy or impair the utility of-----², and the public investment therein. Accordingly, it is declared:

- (1) that the creation or establishment of an obstruction has the potential of being a public nuisance and may injure the region served by-----².
- (2) that it is necessary in the interest of the public health, public safety, and general welfare-----⁴ that the creation or establishment of obstructions that are a

hazard to air navigation be prevented; and

- (3) that the prevention of these obstructions should be accomplished, to the extent legally possible, by the exercise of the police power without compensation.

It is further declared that the prevention of the creation or establishment of hazards to air navigation, the elimination, removal, alteration or mitigation of hazards to air navigation, or the marking and lighting of obstructions are public purposes for which a political subdivision may raise and expend public funds and acquire land or interests in land.

IT IS HEREBY ORDAINED BY _____⁵ as follows:

SECTION I: SHORT TITLE

This Ordinance shall be known and may be cited as-----
²/Zoning Ordinance.

SECTION II: DEFINITIONS

As used in this Ordinance, unless the context otherwise requires:

1. AIRPORT - -----²
2. AIRPORT ELEVATION - The highest point of an airport's usable landing area measured in feet from sea level.
3. APPROACH SURFACE - A surface longitudinally centered on the extended runway centerline, extending outward and upward from the end or the primary surface and at the same slope as the approach zone height limitation slope set forth in Section IV of this Ordinance. In plan the perimeter of the approach surface coincides with the perimeter of the approach zone.
4. APPROACH, TRANSITIONAL, HORIZONTAL, AND CONICAL ZONES - These zones are set forth in Section III of this Ordinance.
5. BOARD OF ADJUSTMENT - A Board consisting of---⁶ members appointed by the ----⁶ as provided in-----⁶.

6. CONICAL SURFACE - A surface extending outward and upward from the periphery of the horizontal surface at a slope of 20 to 1 for a horizontal distance of 4 000 feet.

7. HAZARD TO AIR NAVIGATION - An obstruction determined to have a substantial adverse effect on the safe and efficient utilization of navigable airspace.

8. HEIGHT - For the purpose of determining the height limits in all zones set forth in this Ordinance and shown on the zoning map, the datum shall be mean sea level elevation unless otherwise specified.

9. HELIPORT PRIMARY SURFACE - The area of the primary surface coincides in size and shape with the designated takeoff and landing area of a heliport. This surface is a horizontal plane at the elevation of the established heliport elevation.

10. HORIZONTAL SURFACE - A horizontal plane 150 feet above the established airport elevation, the perimeter of which in plan coincides with the perimeter of the horizontal zone.

11. LARGER THAN UTILITY RUNWAY - A runway that is constructed for and intended to be used by propeller driven aircraft of greater than 12,500 pounds maximum gross weight and jet powered aircraft,

12. NONCONFORMING USE - Any pre-existing structure, object of natural growth, or use of land which is inconsistent with the provisions of this Ordinance or an amendment thereto.

13. NONPRECISION INSTRUMENT RUNWAY - A runway having an existing instrument approach procedure utilizing air navigation facilities with only horizontal guidance, or area type navigation equipment, for which a straight-in nonprecision instrument approach procedure has been approved or planned,

14. OBSTRUCTION - Any structure, growth, or other object, including a mobile object, which exceeds a limiting height set forth in Section *IV* of this Ordinance.

15. PERSON - An individual, firm, partnership, corporation, company, association, joint stock association, or governmental

entity; includes a trustee, a receiver, an assignee, or a similar representative of any of them.

16. PRECISION INSTRUMENT RUNWAY - A runway having an existing instrument approach procedure utilizing an Instrument Landing System (ILS) or a Precision Approach Radar (PAR), It also means a runway for which a precision approach system is planned and is so indicated on an approved airport layout plan or any other planning document.

17. PRIMARY SURFACE - A surface longitudinally centered on a runway. When the runway has a specially prepared hard surface, the primary surface extends 200 feet beyond each end of that runway; for military runways or when the runway has no specially prepared hard surface, or planned hard surface, the primary surface ends at each end of that runway, The width of the primary surface is set forth in Section III of this Ordinance. The elevation of any point on the primary surface is the same as the elevation of the nearest point on the runway center line .

18. RUNWAY - A defined area on an airport prepared for landing and take off aircraft along its length.

19. STRUCTURE - An object, including a mobile object, constructed or installed by man, including but without limitation, buildings, towers, cranes, smoke tacks, earth formation, and overhead transmission lines.

20. TRANSITIONAL SURFACES - These surfaces extend outward at 90 degree angles to the runway centerline and the runway centerline extended at a slope of seven (7) feet horizontally for each foot vertically from the sides of the primary and approach surfaces to where they intersect the horizontal and conical surfaces. Transitional surfaces for those portions of the precision approach surfaces, which project through and beyond the limits of the conical surface, extend a distance of 5, 000feet measured horizontally from the edge of the approach sw--face and at 90 degree angles to the extended runway center l i.ne.

21. TREE - Any object of natural growth.

22. UTILITY RUNWAY - A runway that is constructed for and intended to be used by propeller driven aircraft of 12 ,500 pounds maximum gross weight and less.

23. VISUAL RUNWAY - A runway intended solely for the operation of aircraft using visual approach procedures.

1/ This title should be written to meet the usages and legal requirements of your state, and the political subdivision.

2/ Insert the name of the airport being zoned by the Ordinance.

3/ This citation should be made to conform to the usual method of citing your state laws.

4/ If other terms are commonly used by the courts of your state in defining the limits of police power, such as "convenience or "property", they should be added here.

5/ A form of enacting clause commonly used by the political subdivision adopting ordinances should be followed.

6/ Insert the number of members appointed to the Board of Adjustment, the appointing body, and the enabling legislation authorizing same

SECTION III: AIRPORT ZONES

In order to carry out the provisions of this Ordinance, there are hereby created and established certain zones which include all _____ of the land lying beneath the approach surfaces, transitional surface, horizontal surface, and conical surfaces as they apply to---². Zoning map consisting of----- sheets, prepared by ----, and dated -----¹⁹--- which is attached to this Ordinance and made a part hereof.

An area located in more than one (1) of the following zones is considered to be only in the zone with the more restrictive height limitation. The various zones are hereby established and defined as follows:

1. Utility Runway Visual Approach Zone - The inner edge of this approach zone coincides with the width of the primary surface is -----⁷ feet wide. The approach zone expands outward uniformly to a width of 1,250 feet at a horizontal distance of 5,000 feet from the primary surface. Its centerline is the continuation of the centerline of the runway.
-

7. *Insert dimension as set forth in FAR Part 77. Where more than one dimension is applicable, insert dimension identified to the appropriate runway involved.*

2. Utility Runway Nonprecision Instrument Approach Zone - The inner edge of this approach zone coincides with the width of the primary surface and is 500 feet wide. The approach zone expands outward uniformly to a width of 2,000 feet at a horizontal distance 5,000 feet from the primary surface. Its centerline is the continuation of the centerline of the runway.
3. Runway Larger Than Utility Visual Approach Zone - The inner edge of this approach zone coincides with the width of the primary surface and is 750 feet wide. The approach zone expands outward uniformly to a width of 1,500 feet at a horizontal distance of 5,000 feet from the primary surface. Its centerline is the continuation of the centerline of the runway.
4. Runway Larger Than Utility With A Visibility Minimum Greater Than 3/4 Mile Nonprecision Instrument Approach Zone - The inner edge of this approach zone coincides with the width of the primary surface and is 750 feet wide. The approach zone expands outward uniformly to a width of 3,500 feet at a horizontal distance of 10,000 feet from the primary surface. Its centerline is the continuation of the centerline of the runway.
5. Runway Larger Than Utility With A Visibility Minimum As Low As 3/4 Mile Nonprecision Instrument Approach Zone - The inner edge of this approach zone coincides with the width of the primary surface and is 1,000 feet wide. The approach zone expands outward uniformly to a width of 4,000 feet at a horizontal distance of 10,000 feet from the primary surface. Its centerline is the continuation of the centerline of the runway.
6. Precision Instrument Runway Approach Zone - The inner edge of this approach zone coincides with the width of the primary surface and is 11 000 feet wide. The approach zone expands outward uniformly to a width of 16,000 feet at a horizontal distance of 50,000 feet from the primary

surface, Its centerline is the continuation of the center-line of the runway.

7. Heliport Approach Zone - The inner edge of this approach zone coincides with the width of the primary surface and is---^{8/} feet wide. The approach zone expands outward uniformly to a width of 500 feet at a horizontal distance of 4,000 feet from the primary surface.
 8. Transitional Zones - The transitional zones are the areas beneath the transitional surfaces.
-

8/ The size of the heliport primary surface must be based on present and future heliport operations.

9. Heliport Transitional Zones - These zones extend outward from the sides of the primary surface and the heliport approach zones a horizontal distance of 250 feet from the primary surface centerline and the heliport approach zone centerline.
 10. Horizontal Zone - The horizontal zone is established by swinging arcs of---^{9/} feet radii from the center of each end of the primary surface of each runway and connecting the adjacent arcs by drawing lines tangent to those arcs. The horizontal zone does not include the approach and transitional zones.
 11. Conical Zone - The conical zone is established as the area that commences at the periphery of the horizontal zone and extends outward therefrom a horizontal distance of 4,000 feet.
-

(9) The radius of arc is:

1. *5,000 feet for all runways designated utility or visual,*
2. *10,000 feet for all others.*

The radius of the arcs for each end of the runway shall be the same.

The radius used shall be the longest determined for either end.

SECTION IV: AIRPORT ZONE HEIGHT LIMITATIONS

Except as otherwise provided in this Ordinance, no structure shall be erected, altered, or maintained, and no tree shall be allowed to grow in any zone created by this Ordinance to a height in excess of the applicable height limit herein established for such zone. Such applicable height limitations are hereby established for each of the zones in question as follows:

1. Utility Runway Visual Approach Zone - Slopes twenty (20) feet outward for each foot upward beginning at the end of and at the same elevation as the primary surface and extending to a horizontal distance of 5,000 feet along the extended runway centerline.
2. Utility Runway Nonprecision Instrument Approach Zone - Slope twenty (20) feet outward for each foot upward beginning at the end of and at the same elevation as the primary surface and extending to a horizontal distance of 5,000 feet along the extended runway centerline.
3. Runway Larger Than Utility Visual Approach Zone - The inner edge of this approach zone coincides with the width of the primary surface and is 75 feet wide. The approach zone expands outward uniformly to a width of 1,500 feet at a horizontal distance of 5,000 feet from the primary surface. Its centerline is the continuation of the centerline of the runway.
4. Runway Larger Than Utility With A Visibility Minimum Greater Than 3/4 Mile Nonprecision Instrument Approach Zone - Slope thirty four (34) feet outward for each foot upward beginning at the end of and at the same elevation as the primary surface and extending to a horizontal distance of 10,000 feet along the extended runway centerline.

5. Runway Larger Than Utility With A Visibility Minimum As Low As 3/4 Mile Nonprecision Instrument Approach Zone - The inner edge of this approach zone coincides with the width of the primary surface and is 1,000 feet wide. The approach zone expands outward uniformly to a width of 4,000 feet at a horizontal distance of 10,000 feet from the primary surface. Its centerline is the continuation of the centerline of the runway.
6. Precision Instrument Runway Approach Zone - Slopes fifty (50) feet outward for each foot upward beginning at the end of and at the same elevation as the primary surface and extending to a horizontal distance of 10,000 feet along the extended runway centerline; thence slopes upward forty (40) feet horizontally for each foot vertically to an additional horizontal distance of 40,000 feet along the extended runway centerline.
7. Heliport Approach Zone - Slopes eight (8) feet outward for each foot upward beginning at the end of and at the same elevation as the primary surface and extending to a distance of 4,000 feet along the heliport approach zone centerline.
8. Transitional Zones - Slope seven (7) feet outward for each foot upward beginning at the sides of and at the same elevation as the primary surface and the approach surface, and extending to a height of 150 feet above the airport elevation which is _____ feet above mean sea level. In addition to the foregoing, there are established height limits sloping seven (7) feet outward for each foot upward beginning at the sides of and at the same elevation as the approach surface, and extending to where they intersect the conical surface. Where the precision instrument runway approach zone projects beyond the conical zone, there are established height limits sloping seven (7) feet outward for each foot upward beginning at the sides of and at the same elevation as the approach surface, and extending a horizontal distance of 5,000 feet measured at 90 degree angles to the extended runway centerline.
9. Heliport Transitional Zones - Slope two (2) feet outward for each foot upward beginning at the sides of and at the same

elevation as the primary surface and the heliport approach zones and extending a distance of 250 feet measured horizontally from and at 90 degree angles to the primary surface centerline and heliport approach zones centerline.

10. Horizontal Zone - Established at 150 feet above the airport elevation or at a height of feet- above mean sea level
11. Conical Zone - Slopes t-wenty (20) feet outward for each foot upward beginning at the periphery of the horizontal zone and at 150 feet above the 2irport elevation and extending to a height of 350 feet above the airport elevation.
12. Excepted Height Limitations - Nothing in this Ordinance shall be construed as prohibiting the construction or maintenance of any structure, or growth of any tree to a height up to ¹⁰/ feet above the surface of the land.

SECTION V: USE RESTRICTIONS

Notwithstanding any other provisions of this Ordinance, no use may be made of land or water within any zone established by this Ordinance in such a manner as to create electrical interference with navigational signals or radio communication between the airport and aircraft, make it difficult for pilots to distinguish between airport lights and others, result in glare in the eyes of pilots using the airport, impair visibility in the vicinity of the airport, create bird strike hazards, or otherwise in any way endanger or interfere with the landing, takeoff, or maneuvering of aircraft intending to use the airport.

SECTION VI: NONCONFORMING USES

1. Regulations Not Retroactive - The regulations prescribed by this Ordinance shall not be construed to require the removal, lowering, or other change or alteration of any structure or tree not conforming to the regulations as of the effective date of this Ordinance, or otherwise interfere with the continuance of nonconforming use. Nothing contained herein shall require any change in the construction, alteration, or intended use of any structure, the construction or alteration of which was begun prior to

the effective date of this Ordinance, and is diligently prosecuted.

2. Marking and Lighting - Notwithstanding the preceding provision of this Section, the owner of any existing nonconforming structure or tree is hereby required to permit tile installation, operation, and maintenance thereon of such markers and lights as shall be deemed necessary by the----^{11/} to indicate to the operators of aircraft in the vicinity of the airport the presence of such airport obstruction. Such markers and lights shall be installed, operated, and maintained at the expense of the - - - -^{1 2} .

10/ *The adoption of height limits should be reasonable and based on land use considerations in the vicinity of the airport and the nature of the area to be zoned. The adoption of height limits shoulr not be so low as to constitute a taking of private property without due process of law.*

11/ *Insert the title of the appropriate official who has been charged with the responsibility for determining the necessity for marking and lighting.*

12. *Insert the name of the appropriate political body or subdivision.*

SECTION VII: PERMITS

1. Future Uses - Except as specifically provided in a, b, and c hereunder, no material change shall -be made in the use of land, no structure shall be erected or otherwise established, and no tree shall be planted in any zone hereby created unless a permit therefor shall have been applied for and granted. Each application for a perm.it shall indicate the purpose for which the permit is desired with sufficient particularity to permit it to be determined whether the resulting use, structure, or tree would conform to the regulations herein prescribed. If such determination is in the affirmative, the permit shall be granted. No permit for a use inconsistent with the provisions of this Ordinance shall be granted unless a variance has been approved in accordance with Section VII, 4.
 - a. In the area lying within the limits of the horizontal zone and conical zone, no permit shall be required for any tree or structure less than seventy-five feet of vertical height above

the ground, except when, because of terrain, land contour, or topographic features, such tree or structure would extend above the height limits prescribed for such zones.

- b. In areas lying within the limits of the approach zones, but at a horizontal distance of not less than 4,200 feet from each end of the runway, no permit shall be required for any tree or structure less than seventy-five feet of vertical height above the ground, except when such tree or structure would extend above the height limit prescribed for such approach zones.
- c. In the areas lying within the limits of the transition zones beyond the perimeter of the horizontal zone, no permit shall be required for any tree or structure less than seventy-five feet of vertical height above the ground, except when such tree or structure, because of terrain, land contour or topographic features, would extend above the height limit prescribed for such transition zones.

Nothing contained in any of the foregoing exceptions shall be construed as permitting or intending to permit any construction, or alteration of any structure, or growth of any tree in excess of any of the height limits established by this Ordinance except as set forth in Section IV, 12.

- 2. Existing Uses - No permit shall be granted that would allow the establishment or creation of an obstruction or permit a nonconforming use, structure, or tree to become a greater hazard to air navigation than it was on the effective date of this Ordinance or any amendments thereto or that it is when the application for a permit is made. Except as indicated, all applications for such a permit shall be granted.
- 3. Nonconforming Uses Abandoned or Destroyed - Whenever the ---^{13/} determines that a nonconforming tree or structure has been abandoned or more than 80 percent torn down, physically deteriorated, or decayed, no permit shall be granted that would allow such structure or tree to exceed the applicable height limit or otherwise deviate from the zoning regulation:
- 4. Variances - Any person desiring to erect or increase the height of any structure, or permit the growth of any tree, or use property, not in accordance with the regulations prescribed in this

Ordinance, may apply to the Board of Adjustment¹⁴ for a variance from such regulations. The application for variance shall be accompanied by a determination from the Federal Aviation Administration as to the effect of the proposal on the operation of air navigation facilities and the safe, efficient use of navigable **airspace**. Such variances shall be allowed where it is duly found that a literal application or enforcement of the regulations will **result** in unnecessary hardship and relief granted, will not be contrary to the public interest, will not create a hazard to air navigation, will do substantial justice, and will be in accordance with the spirit of this Ordinance. Additionally, no application for variance to the requirements of this Ordinance may be considered by the Board of Adjustment unless a copy of the application has been furnished to the ---¹⁴/ for advice **as** to the aeronautical effects of the variance. If the ---¹⁴/does not respond to the application within fifteen (15) days after receipt, the Board of Adjustment may act on its own to grant or deny said application.

5. Obstruction Marking and Lighting - Any permit or variance granted may if such action is deemed advisable to effectuate the purpose of this Ordinance and be as onable in the circumstances, be so conditioned as to require the owner of the structure or tree in question to install, operate, and maintain, at the owner expense, such markings and lights as may be necessary. If deemed proper by the Board of Adjustment, this condition may be modified to require the owner to permit the ---¹²/ at its own expense, to install, operate, and maintain the necessary markings and lights.

13/ Insert here the title of the appropriate official charged with making this determination

14/ Insert here the official or body responsible for operation and maintenance of the airport to be zoned.

SECTION VIII: ENFORCEMENT

It shall be the duty of the ---¹⁵/ to administer and enforce the regulations prescribed herein. Application for permits and variances shall be made to the ----¹⁵/ upon a form published for

that purpose. Applications required by this Ordinance to be submitted to the ---¹⁵ / shall be promptly considered and granted or denied. Application for action by the Board of Adjustment shall be forthwith transmitted by the ---¹⁵.

SECTION IX: BOARD OF ADJUSTMENT

1. There is hereby created a Board of Adjustment to have and exercise the following powers: (1) to hear and decide appeals from any order, requirement, decision, or determination made by the ---¹⁵/ in the enforcement of this Ordinance; (2) to hear and decide special exceptions to the terms of this Ordinance upon which such Board of Adjustment under such regulations may be required to pass; and (3) to hear and decide specific variances.
2. The Board of Adjustment shall consist of ---members appointed by the --¹²/ and each shall serve for a term of --- years until a successor is duly appointed and qualified. Of the members first appointed, one shall be appointed for a term of --- year, -- for a term of --- years, and --- for a term of ---years": Member shall be removable by the appointing authority for cause, upon written charges, after a public hearing.
3. The Board of Adjustment shall adopt rules for its governance and in harmony with the provisions of this Ordinance. Meetings of the Board of Adjustment shall be held at the call of the Chairperson and at such other times as the Board of Adjustment may determine. The Chairperson or, in the absence of the Chairperson, the Acting Chairperson may administer oaths and compel the attendance of witnesses. All hearings of the Board of Adjustment shall be public. The Board of Adjustment shall keep minutes of its proceedings showing the vote of each member upon each question; or if absent or failing to vote, indicating such fact, and shall keep records of its examinations and other official actions, all of which shall immediately be filed in the office of ---¹⁵ and on due cause shown.
4. The Board of Adjustment shall make written findings of facts and conclusions of law giving the facts upon which it acted and its legal conclusions from such facts in reversing, affirming, or modifying any order, requirement decision or determination which comes before it under the provisions of this Ordinance.

5. The concurring vote of a majority of the members of the Board of Adjustment shall be sufficient to reverse any order, requirement, decision, or determination of the ---^{15/} or decide in favor of the applicant on any matter upon which it is required to pass under this Ordinance, or to effect variation to this Ordinance.
-

15/ Insert here the title of the appropriate official, such as Director, Department of Public Works, etc.

SECTION X: APPEALS

1. Any person aggrieved, or any taxpayer affected, by any decision of the ---^{15/} made in the administration of the Ordinance, may appeal to to Board of Adjustment.
2. All appeals hereunder must be taken within a reasonable time as provided by the rules of the Board of Adjustment, by filing with the ----^{15/} a notice of appeal specifying the grounds thereof. The ----^{15/} shall forthwith transmit to the Board of Adjustment the papers constituting the record upon which the action appealed from was taken.
3. An appeal shall stay all proceedings in furtherance of the action appealed from unless the ----^{15/} certifies to the Board of Adjustment, after the notice of appeal has been filed with it, that by reason of the facts stated in the certificate a stay would in the opinion of ----^{15/} cause imminent peril to life or property. In such case, proceedings shall not be stayed except by the order of the Board of Adjustment on notice to the ----^{15/} and on due cause shown.
4. The Board of Adjustment shall fix a reasonable time for hearing appeals, give public notice and due notice to the parties in interest, and decide the same within a reasonable time. Upon the hearing, any party may appear in person or by agent or by attorney.
5. The Board of Adjustment may, in conformity with the provisions of this Ordinance, reverse or affirm, in whole or in part, or modify the order, requirement, decision, or determination

appealed from and may make such order, requirement, decision, or determination as may be appropriate under the circumstances.

SECTION XI: JUDICIAL REVIEW

Any person aggrieved, or any taxpayer affected, by any decision of the Board of Adjustment, may appeal to the Court of _____ as provided in Section ---- of Chapter --- of the Public Laws of ----^{16/}

16/ Insert the jurisdiction. Consideration should be given the desirability of setting forth this procedure here, or as an alternative attaching to all copies of this Ordinance, a copy of excerpts from the statute cited.

SECTION XII: PENALTIES

Each violation of this Ordinance or of any regulation, order, or ruling promulgated hereunder shall constitute a misdemeanor and shall be punishable by a fine of not more than --- dollars or imprisonment for not more than days or both, and each day a violation continues to exist shall constitute a separate offense.

SECTION XIII: CONFLICTING REGULATIONS

Where there exists a conflict between any of the regulations or limitations prescribed in this Ordinance and any other regulations applicable to the same area, whether the conflict be with respect to the height of structures or trees, and the use of land, or any other matter, the more stringent limitation or requirement shall govern and prevail.

SECTION XIV: SEVERABILITY

If any of the provisions of this Ordinance or the application thereof to any person or circumstances are held invalid, such invalidity shall not affect other provisions or applications of the Ordinance which can be given effect without the invalid provision or application, and to this end, the provisions of this Ordinance are declared to be severable.

SECTION XV: EFFECTIVE DATE

WHEREAS, the immediate operation of the provisions of this Ordinance is necessary for the preservation of the public health, public safety, and general welfare, an EMERGENCY is hereby declared to exist, and this Ordinance shall be in full force and effect from and after its passage by the ----- and publication and posting as required by law. Adopted by the ----- this ----- day of ----- 19--.

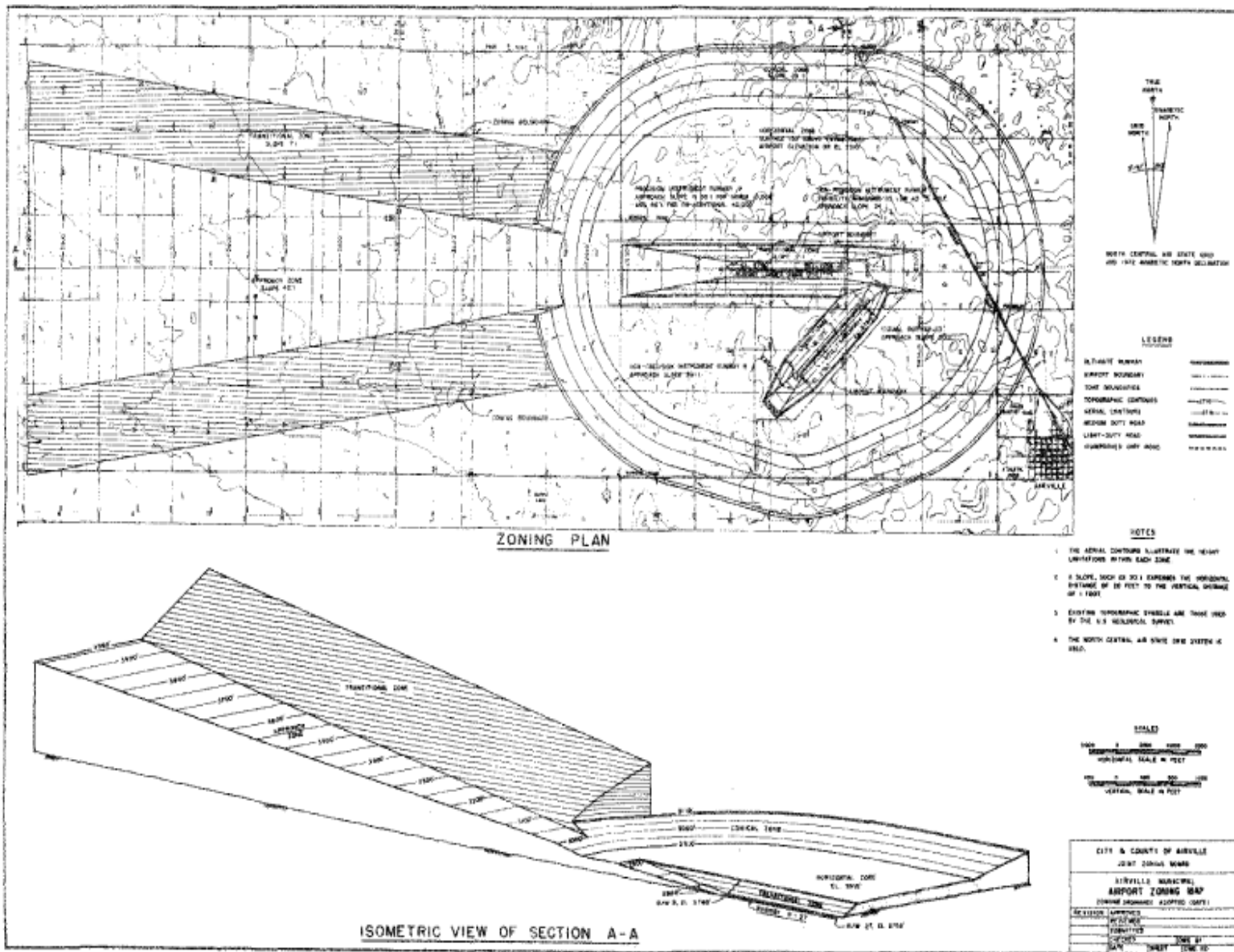

Figure A-2-1

Appendix 3

States' Practices on Shielding

I. ARGENTINA

1.1 It is felt that the shielding principle which is used to permit the erection of new permanent obstacles should not be considered when:

- a) the permanent objects are destined to be erected within the inner 3000 m from the threshold;
- b) they penalize the instrument approach areas although they do not exceed the limits defined by the obstacle limitation surfaces;
- c) though the conditions in b) are satisfied, the available free spaces or areas immediately adjacent to the runway extremities are regarded as extensions of the runway length available or, where applicable, as future stopways;
- d) parallel runways are planned and areas common to instrument approach procedures have to be unified;
- e) there is a question of installation of high-voltage powerlines, fuel storage facilities, etc.;
- f) in the case of a frangible object, its height has been designed so as to ensure vertical clearance by aircraft;
- g) in case of planned instrument approaches, the type of implementation and probable operating procedure have not been defined.

1.2 As a corollary it may be added that the shielding principle should only operate in relation to the highest permanent obstacle in the area. Any new installation that may be erected in its vicinity should be related to that obstacle and in no case to permanent obstacles of minor height in the area. The only exceptions to this principle, when other criteria should be considered, are cases where associated topographical features exist in the area. In these cases account must be taken not only of the obstacle limitation surfaces described in MAS 1, but also of the height limitations established for instrument approach procedures.

2. AUSTRALIA

2.1 *Take-off climb and approach surfaces.* Where the surface is significantly obstructed by other than isolated obstacles, new obstacles are permitted up to the height of the lowest permanent obstacle within 60 m, provided that the new obstacle is surrounded by existing obstacles and that the new obstacle does not

become the critical obstacle. The critical obstacle is that obstacle which subtends the greatest angle when measured from the end of the strip.

2.2 *Transitional surfaces.* Where permanent obstacles already infringe the transitional surfaces, new obstacles are permitted up to the same height, provided that they are further away from the edges: of the strip or the approach area and are shielded by the existing obstacles.

2.3 *Horizontal and conical surfaces.* Where permanent obstacles already infringe the horizontal or conical surfaces, new obstacles are permitted up to the same height, provided that they are further away from the aerodrome reference point, and are shielded by existing obstacles.

3. FRANCE

3.1 *Shielding of narrow objects by bulky objects.* The potential hazard of a narrow obstacle is lessened when it is shielded by a bulky obstacle. As regards such narrow obstacles, they shall be considered to be shielded when they remain below the enveloping surface of the semi-planes tangential to the top of the bulky obstacle covering them, with a 15 per cent descending slope situated around that obstacle. The shielded obstacles, in particular parts of tines or cables, do not need to be removed or modified.

3.2 *Adjacent electric lines.* The provisions in the above paragraph may also be less stringent in the particular case of adjacent electric lines, i.e. those that are within the "corridor" of another line. The "corridor" of an electric line is determined by the vertical planes parallel to the median planes of the successive parts of the cable, situated respectively on either side of these parts at a distance of 150 m for daytime marking and 300 m for night-time marking. The segment of a first line is shielded by a second electric line when:

- a) this segment is adjacent to the second electric line;
- b) this segment is lower than the segment of the second cable delineated by the same planes.

On take-off areas, electric lines, although adjacent, shall be marked as if they were isolated when their median planes are at a distance of over 50 m. For all other locations, no marking is required for the segment of an electric line which is shielded by another electric line. In cases where there are more than two lines close to each other, consideration should be given to whether it is necessary to mark the two outside lines, notwithstanding the above shielding provisions. Lastly, special consideration should be given to cases where a large number of lines which are more or less parallel cover a large area and might consequently be a special hazard.

3.3 *Application of the foregoing provisions.* The following situations call for more stringent treatment than the above:

- a) the lines or cables meet the clearance requirements but are hazardous to air navigation as a result of local conditions or the type of air traffic involved, and must consequently be modified or removed;
- b) the lines or cables are not located within one of the zones where marking is required, but are a possible danger to air navigation, and can be tolerated only if they are marked.

4. INDIA

4.1 In India, the principle of shielding is not applied in the areas covered by the transitional surface, the inner horizontal surface up to a distance of 2500 m from the aerodrome reference point (ARP), or the approach/take-off climb area up to a distance of 3000 m from its inner edge.

4.2 In areas other than those described above, the principle of shielding will be applied using a negative slope of 10 per cent from the top of the authorized existing buildings/structures causing obstruction, when projected towards the runway, and on a horizontal plane when projected away from the runway.

5. SPAIN

5.1 The principle of shielding is used in certain cases to authorize the construction of buildings or installations which, although they exceed the obstacle limitation surfaces, can be considered to be shielded by other natural or artificial obstacles already existing. An object is considered to be shielded when:

- a) it is situated below a plane passing through a point of the obstacle serving as a shield and has a negative slope of 10 per cent in any direction with respect to the aerodrome, except in the direction opposite thereto, and at a horizontal distance not exceeding 150 m: and
- b) it is located within the volume created by the horizontal translation of the contours of the obstacle serving as a shield. in the opposite direction to the aerodrome, and at a horizontal distance of not more than 150 m from that obstacle.

5.2 In general, power and communication lines are not considered as shielding obstacles

6. UNITED STATES OF AMERICA

6.1 The principle of shielding as applied to obstacles to air navigation may minimize the requirements for marking and lighting such shielded obstacles, and may reduce the necessity for removing obstacles or prohibiting the construction

of new constructions.

6.2 An object should not be considered an obstacle if its location with respect to obstacles of a permanent character is such that there results no material increase in the aeronautical hazard. In the determination of whether an object is shielded, each obstacle of a permanent character, located in the runway approach-departure area, is regarded as casting a shadow plane outward away from the runway end. Thus, an object shielded by the shadow plane of a governing obstacle will not be considered as an obstacle.

6.3 *Marking and lighting.* Portions of obstacles that are shielded by surrounding objects need not be marked or lighted, but the surrounding objects; should be marked and lighted.

a) *Extensive obstacles.* When the upper part of only a portion of a building or similar extensive obstacle projects above an obstacle-determining surface, that part only need be obstacle-marked, and the point or edge of it highest in relation to the obstacle-determining surface should be regarded as the top of the obstacle. In certain cases, however, such as when the obstacle-determining surface concerned is a sloping surface (as the approach surface, or transitional surface), this point or edge highest in relation to the obstacle-determining surface may not be the highest point or edge above a horizontal plane passing through the base of the object. In such cases, those portions of the object, the upper parts of which are higher above a horizontal plane passing through the base of the object than the upper part considered as the top of the obstacle, should also be obstacle-marked.

b) *Group of obstacles.* In the event the individual objects of a group of obstacles are approximately the same overall height above the terrain and are located not more than 45 m apart, the group of obstacles may be considered an extensive obstacle and so obstacle-marked /lighted.

Towers, poles, tanks, smoke-stacks and similar obstacles, which are so grouped as to present a common hazard to air navigation, should be marked/lighted as an extensive obstacle if of approximately the same overall height. Where spacing between individual structures is not less than 45 m, whether of the same or different overall height, each prominent object within the group should be marked/lighted. In addition, at the top of a prominent centre obstacle, at least one rotating beacon should be installed, providing a red flashing light.

c) *Shielding of obstacle marking/lighting by another object.* Another feature of shielding concerns the blocking out or shielding of an obstacle light by another object. If a light which is installed on an obstacle is shielded in any direction by an adjacent object, additional lights should be mounted on that object in such a way as to retain the general definition of the obstacle, the shielded light being omitted if it does not contribute to the definition of the obstacle.

6.4 *Removal or restriction of construction of obstacles.* The national aviation authority must be notified when certain proposed structures are to be constructed or existing structures are to be altered, so that the effect of such structures on air navigation can be determined. Among the structures excepted from this requirement are shielded objects.

a) *Shielded objects.* No notification is required for any object that would be shielded by existing structures of a permanent and substantial character or by natural terrain or topographic features of equal or greater height, and would be located in the congested area of a city, town, or settlement where it is evident beyond all reasonable doubt that the structure so shielded will not adversely affect safety in air navigation.

b) *Antenna farms.* An antenna farm area consists of a specified geographical location with established dimensions of area and height, where antenna towers with a common impact on aviation may be grouped. The use of antenna farms is an application of the shielding principle. Usage of antenna farms and the single-structure/multiple-antenna concept for radio and television towers, wherever possible, is to be encouraged.
